

# WALKER

## Operator's Manual

Safety, Assembly, Operating, and Maintenance Instructions



# R22

**Please Read and Save These Instructions**

For Safety, Read All Safety and Operation  
Instructions Prior to Operating Machine

Beginning S/N: 189149  
P/N: 1000-10

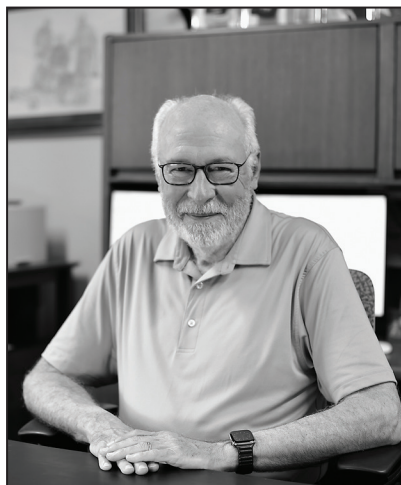

## Foreword

**Thank you.** . .for purchasing a Walker mower. Every effort has been made to provide you with the most reliable mower on the market, and we are sure you will be among our many satisfied customers. If for any reason this product does not perform to your expectations, please contact your local dealer. Every customer is important to us. Your satisfaction is our goal.

**Please.** . .read this manual thoroughly! This manual is to be used in conjunction with the engine manufacturer's manual for the specific engine on the mower model you have purchased. Before you operate your new mower, please read this entire manual. Some of the information is crucial for proper operation and maintenance of this mower - it will help protect your investment and ensure that the mower performs to your satisfaction. Some of the information is important to your safety, and must be read and understood to help prevent possible injury to the operator or others. If anything in this manual is confusing or hard to understand, please contact your local authorized dealer or call our service department, at (970) 221-5614, for clarification before operating or servicing this mower.

This manual covers Model R with the Kohler KT722 (22 HP) Gasoline Engine.

**All shields and guards must be in place for the proper and safe operation of this machine.** Where they are shown removed in this manual, it is for illustration purposes only. **Do not operate this machine unless all shields and guards are in place.**

Specifications given are based on the latest information available at the time this manual was produced for a tractor with standard equipment. Optional equipment is available and may affect the standard specifications listed.

Walker Mfg. Co. is continually striving to improve the design and performance of its products. We reserve the right to make changes in specifications and design without thereby incurring any obligation relative to previously manufactured products.

Sincerely,  
WALKER MANUFACTURING COMPANY

A handwritten signature in black ink that reads "Bob Walker". The signature is written in a cursive, flowing style.

Bob Walker, Chairman

## **General Information** **1**

Highlighted Information.....	1
Glossary .....	2
Servicing of Engine and Transaxle Components...	2
Identifying Number Locations .....	3
Tractor and Deck Identifiers .....	3
Specifications .....	4
Component Identification.....	7

## **Safety Instructions** **10**

Safety Before Operating .....	10
Safety During Operation .....	11
Safety During Maintenance .....	13
Safety, Control, and Instruction Decals .....	14

## **Operating Instructions** **19**

Operator Controls .....	19
Ignition Switch .....	19
Engine Throttle .....	20
Steering Levers .....	20
Forward Speed Control (FSC).....	22
Blade Clutch Switch (PTO).....	22
Parking Brake .....	22
Circuit Breaker.....	22
Seat Panel Latch .....	23
Hourmeter.....	23
Transaxle Lockout Arms .....	23
Pre-Operation Checklist .....	24
Starting the Engine .....	25
Adjusting Ground Speed and Steering .....	25
Recommendations for Getting Started .....	27
Engaging the Blades .....	27
Stopping the Machine.....	28
Adjusting the Cutting Height.....	29
Deck Tilt-Up Position .....	29
Recommendations for Mowing .....	30
Transaxle Lockout .....	32
Recommendations for Towing .....	33
Recommendations for Tilt-up Deck Operation and Transport .....	33

## **Maintenance** **34**

R22 Maintenance Schedule Chart.....	34
-------------------------------------	----

Check Engine Crankcase Oil.....	35
Check/Clean Engine Air Cooling System .....	36
Clean Grass Buildup Under Deck.....	37
Inspect/Service Mower Blades .....	37
Check Security of Air Filtration Components .....	39
Check Discharge Shield .....	39
Lubricate Grease Fittings and Oil Points .....	39
Check Tire Pressure .....	41
Check Drive Belts (Ground Drive, Blade).....	41
Check Safety Switch System.....	41
Clean/Replace Engine Precleaner Air Filter .....	42
Replace Engine Air Filter .....	43
Change Engine Crankcase Oil and Filter .....	44
Clean Engine Cooling System.....	45
Replace Fuel Filter .....	46
Clean Transaxle Housing and Fans .....	46
Check Drive Tire Mounting Nuts.....	47
Check Blade Brake Function .....	47
Replace Spark Plugs and Set Gap.....	47
Check/Adjust Engine Valve Lash.....	47
Check FSC Friction Lock.....	48
Check Transmission Control Settings.....	48
Check Neutral-Park Position .....	48
Check Straight Ground Tracking .....	48
Check Fuel Lines and Clamps.....	48
Clean Battery Terminals .....	49
Charge Battery .....	49
Long-Term Storage Preparation .....	50
Mower Preparation for Storage .....	50
Engine Preparation for Storage .....	50
Restarting the Mower After Storage .....	50

## **Service and Adjustments** **51**

Belt Replacement .....	51
Replacing the Blade Drive Belt (PTO).....	52
Replacing the Ground Drive Belt.....	54
Deck Leveling .....	57
Steering Handle Adjustment.....	58
Forward Speed Control Friction Adjustment.....	58
Neutral Function Adjustment .....	59
Straight Tracking Adjustment.....	60
Maximum Forward Speed Adjustment.....	60

**Appendix: Assembly Instructions      61**

Assembling the Tractor.....61  
Assembling the Deck.....62  
Deck Caster Wheel Installation .....62  
Tilt-Up Roller Wheel Installation .....62  
Installing the Deck .....63

# General Information

## In this section...

Highlighted Information .....	1
Glossary .....	2
Identifying Number Locations.....	3
Specifications .....	4
Component Identification.....	7

### Highlighted Information

Throughout this guide you will find important information labeled **DANGER, WARNING, CAUTION, IMPORTANT, and NOTE**. Pay particular attention to the information provided for your safety and the safety and longevity of your equipment.

When you see the Safety Alert Symbol (  ), read, understand, and follow the instructions. Failure to comply with safety instructions may result in personal injury.

The seriousness or degree of importance of each type of information is defined as follows:

#### **DANGER**

An **IMMEDIATE** hazard that **WILL** result in severe personal injury or **DEATH**, if warning is ignored and proper safety precautions are not taken.

#### **WARNING**

A **POTENTIAL** hazard that **COULD** result in severe personal injury or **DEATH**, if warning is ignored and proper safety precautions are not taken.

#### **CAUTION**

Possible hazards or unsafe practices that **MAY** result in **MODERATE** personal injury or property damage, or machine damage, if warning is ignored and proper safety precautions are not taken.

**IMPORTANT:** Identifies mechanical information demanding special attention, since it deals with the possibility of damaging a part or parts of the machine.

**NOTE:** Identifies information worthy of special attention.

Walker Manufacturing cannot predict every potentially dangerous situation. Therefore, items labeled as such in this manual do not cover all conceivable situations. Most accidents associated with the operation or maintenance of a Walker Mower are caused by disregarding basic safety precautions or specific warnings. Such accidents, in most cases, can be prevented by being aware of the dangers present. Any person using procedures, tools, or control techniques not recommended by Walker Manufacturing must take full responsibility for safety.

Walker Manufacturing recommends that any service requiring special training or tools be performed by an authorized Walker Mower dealer.

## Glossary

---

There are many terms that are either unique to this equipment or that are used as acronyms. The following terms and their definitions will help while using this manual:

- **DECK** is the mowing attachment mounted on the front of the tractor which includes the carrier frame, deck housing, belt or gear drive components, and cutter blades.
- **FORWARD SPEED CONTROL (FSC)** controls the maximum forward speed of the tractor, functions as a cruise control, and provides a NEUTRAL-PARK function to stop the mower.
- **GROUND DRIVE** refers to the dual transaxles which drive the main wheels.
- **LEFT HAND (LH)** refers to the left-hand side of the tractor when the operator is seated facing forward in the tractor seat.
- **POWER TAKE-OFF (PTO)** transmits engine power to run the cutter blades.
- **RIGHT HAND (RH)** refers to the right-hand side of the tractor when the operator is seated facing forward in the tractor seat.
- **SIDE DISCHARGE (SD)** discharges mowed material from the right side of the mower deck.
- **STEERING LEVERS** steer the tractor by controlling the two transaxles.
- **TRACTOR** is the prime mover, including the engine, drivetrain, operator seat, and controls to operate the mower.
- **TRANSAXLE** transmits and controls power from the ground drive belt to the main drive wheel.
- **TRANSAXLE LOCKOUT ARMS** release the transaxles to permit freewheeling the tractor.

## Servicing of Engine and Transaxle Components

---

The detailed servicing and repair of the engine and transaxles are not covered in this manual. Only routine maintenance and general service instructions are provided. For the service of these components during the limited warranty period, it is important to find a local, authorized servicing agent of the component manufacturer. **Any unauthorized work done** on these components during the warranty period **may void the warranty**. If you have any difficulty finding an authorized outlet or obtaining warranty service, please contact our Service Department for assistance:

### Walker Manufacturing Company

5925 E. Harmony Road  
Fort Collins, CO 80528  
1-970-221-5614  
[www.walker.com](http://www.walker.com)

Service manuals are available for each of these components from their respective manufacturers as follows:

Kohler Engines

### Kohler Company

Kohler, WI 53044  
800-544-2444  
[www.kohlerengines.com](http://www.kohlerengines.com)

Transaxles

### Hydro-Gear

1411 South Hamilton St.  
Sullivan, IL 61951  
877-728-7410  
[www.hydro-gear.com](http://www.hydro-gear.com)

### Identifying Number Locations

The tractor serial number plate is affixed to the tractor chassis behind the seat. The mower deck serial number plate is affixed alongside the angle iron framing on the left beside the belt cover. The engine serial number is on right side of the engine. Model and serial numbers are helpful when obtaining replacement parts and maintenance assistance. For ready reference, please record these numbers in the space provided.

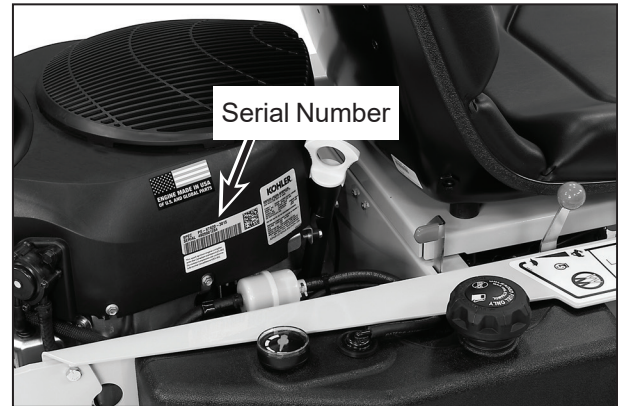

Engine Serial Number Location

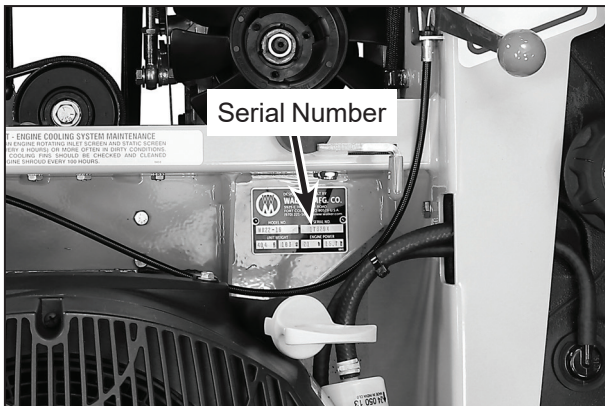

Tractor Serial Number Location

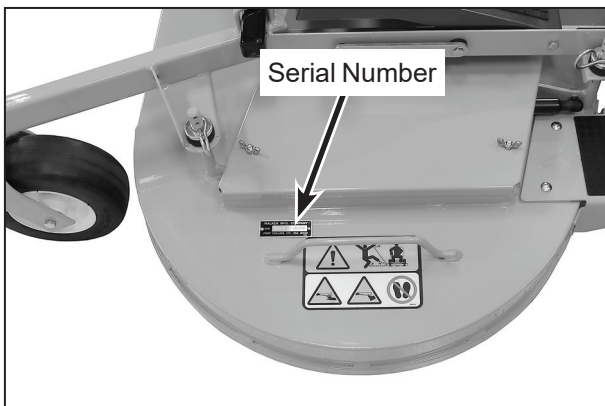

Mower Deck Serial Number Location

### Tractor and Deck Identifiers

Tractor Model No. \_\_\_\_\_

Tractor Serial No. \_\_\_\_\_

Deck Serial No. \_\_\_\_\_

Engine Model No. \_\_\_\_\_

Engine Serial No. \_\_\_\_\_

Date of Purchase \_\_\_\_\_

---

## Specifications

---

### DIMENSIONS

#### Length in. (cm)

Tractor Wheel Base	39 (99)
Tractor with Tilted 42" Deck	74 (188)
Tractor with 42" Deck	88 (224)
Tractor with 48" Deck	91 (231)
Tractor with 54" Deck	90 (229)

#### Width in. (cm)

Tractor Only (Outside Tire)	39 (99)
Tractor with 42" Deck (with Discharge Shield Raised)	43 (109)
Tractor with 48" Deck (with Discharge Shield Raised)	49 (124)
Tractor with 54" Deck (with Discharge Shield Raised)	55 (140)

#### Height in. (cm)

Tractor	42 (107)
---------	----------

#### Weight lb (kg)

Tractor Only	404 (183)
Tractor with 42" Deck	575 (261)
Tractor with 48" Deck	593 (269)
Tractor with 54" Deck	622 (282)

---

### MOWER DECK

Available Cut Width	42 to 54 in. (107 to 137 cm)
Cutting Height	1.5 to 4 in. (4 to 10 cm) in 1/2 in. (1 cm) Increments
Deck Suspension	Independent Torsion-Flex Frame with Caster Wheels and Counterweight Springs

---

### FRAME/BODY CONSTRUCTION

Frame and Body	All Welded Unitized Steel Chassis, 14 Gauge Steel
Deck	11 Gauge Steel
Seat	Contour-Molded, with Nylon Backed Vinyl Cover and Integral Foam Cushion

---

### TIRE SIZE

Deck Caster Wheel	8 x 3.00-4 (Semi-Pneumatic)
Drive	18 x 8.50-10 (Pneumatic 4-Ply, Low-Profile)



---

**Specifications**

---

**TIRE SIZE (Continued)**

Tailwheel	13 x 6.50-6 (Pneumatic 4-Ply)
-----------	-------------------------------

---

**TIRE PRESSURE PSI (KPA)**

Drive	15 (103)
Tailwheel	20 (137)

---

**ENGINE**

Manufacturer/Model	Kohler KT722
Displacement cu. in. (cc)	45.6 (747)
Max. Power HP (kW)	22 (16.4) @ 3600 RPM
Governed RPM	3600
Max. Torque lb·ft (N·m)	35.9 (48.7)
Idle RPM	1750
Spark Plug Type	Champion® type RC12YC (or equivalent)
Spark Plug Gap in. (mm)	.030 (0.76)
Crankcase Capacity qt (L)	2.0 (1.9)
Crankcase Lubricant (From Factory)	300 Hour, Kohler PRO® Synthetic 10W-50 Kohler P/N 25 357 72-S
Oil Filter (From Factory)	300 Hour, Kohler PRO® Filter P/N 25 050 53-S
Conventional Crankcase Lubricant (Alternative Option)	100 Hour, API SJ or Higher Grade Oil Only with 10W-30 Viscosity Above 0° F (-18° C), or 5W-30 Viscosity Below 32° F (0° C)
Oil Filter (Alternative Option)	200 Hour, Kohler Filter P/N 12-050-01-S
Fuel Tank Capacity gal (L)	3 (11.4)
Fuel	Regular Grade Unleaded Gasoline (87 Octane Minimum, 10% Ethanol Maximum)
Cooling System	Air-Cooled
Air Cleaner	Engine Mounted (Kohler) Kohler P/N 16 083 04-S (Filter), 16 083 05-S (Precleaner)

---

**ELECTRICAL SYSTEM**

Battery	12 Volt, 300 CCA (Interstate SP-35)
Charging System	Flywheel Alternator
Charging Output	18 Amp DC (Regulated)
System Polarity	Negative Ground
Ignition	Electronic Capacitive Discharge

---

## Specifications

---

### ELECTRICAL SYSTEM (Continued)

Starter	12 Volt Electric, Key and Solenoid Operated
Interlock Switches	Ignition Lockout by Seat Switch, Transmission Neutral, Blade Clutch, Parking Brake, and Deck Arm Lock
Circuit Breaker(s)	Two Fuses (5A) Auto Reset (30A)

---

### BLADE DRIVE

PTO	Single belt
Blade Drive Clutch and Brake	Electric Clutch [Stops Blades within Five (5) Seconds of Disengagement]

---

### DRIVE BELTS

Ground Drive Belt	Walker P/N 1250
Blade Drive Belt	Walker P/N 1731 (48" Deck) Walker P/N 1731-1 (42" Deck) Walker P/N 1731-2 (54" Deck)

---

### TRANSMISSION

Manufacturer/Model	Dual, Independent Hydro-Gear® ZT-2200 EZT Integrated Transaxles
Steering	Hand Lever Control / Individual Wheel
Forward Speed Control	Precision Friction Lock Lever, Cruise Control, with Neutral-Park Position
Service Brake	Dynamic Braking Through Transaxles
Parking Brake	Mechanical Cog Lock for each Transaxle (Single Lever Control)
Neutral	Transmission Release by Manual Dump Valve
Final Drive	Transaxle Direct to Drive Wheel
Transmission Cooling	Cooling Fan Mounted on Drive Pulley
Transmission Fluid	Factory Serviced and Sealed (No Maintenance)

### GROUND TRAVEL SPEED

Forward MPH (km/h)	0-6 (0-10) Infinitely Variable
Reverse MPH (km/h)	0-6 (0-10) Infinitely Variable

---

### TOWING

Towing Capacity lb (kg)	250 (113) if equipped with a factory authorized tow hitch
-------------------------	---

**NOTE:** The manufacturer reserves the right to make changes in specifications shown herein at any time without notice or obligation. The specifications listed are for a standard configuration tractor, and may change with the addition of optional equipment.

### Component Identification

This section identifies the main features of the R22. Control features are identified and explained in the section "Operator Controls" on page 19.

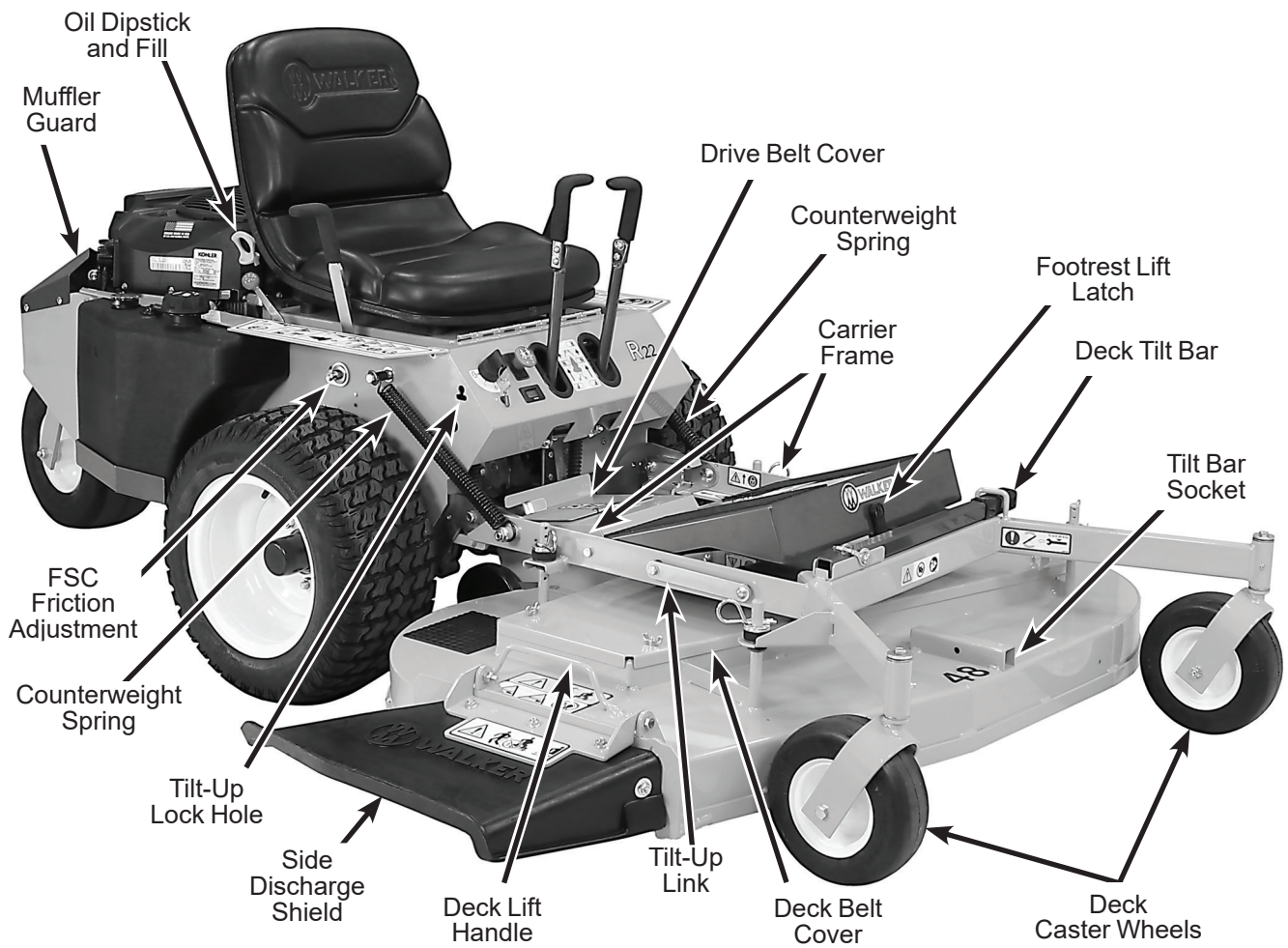

Front View and Right Side View

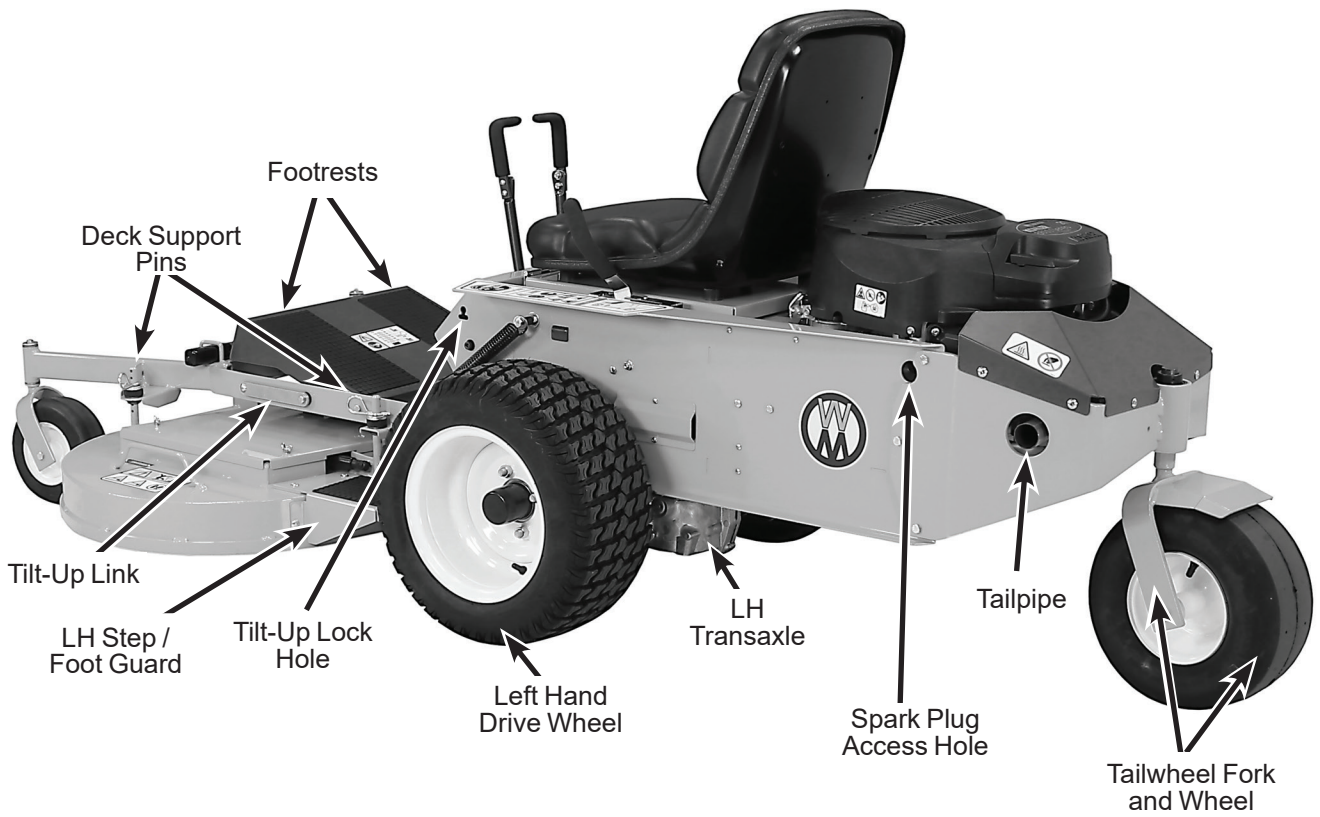

Rear View and Left Side View

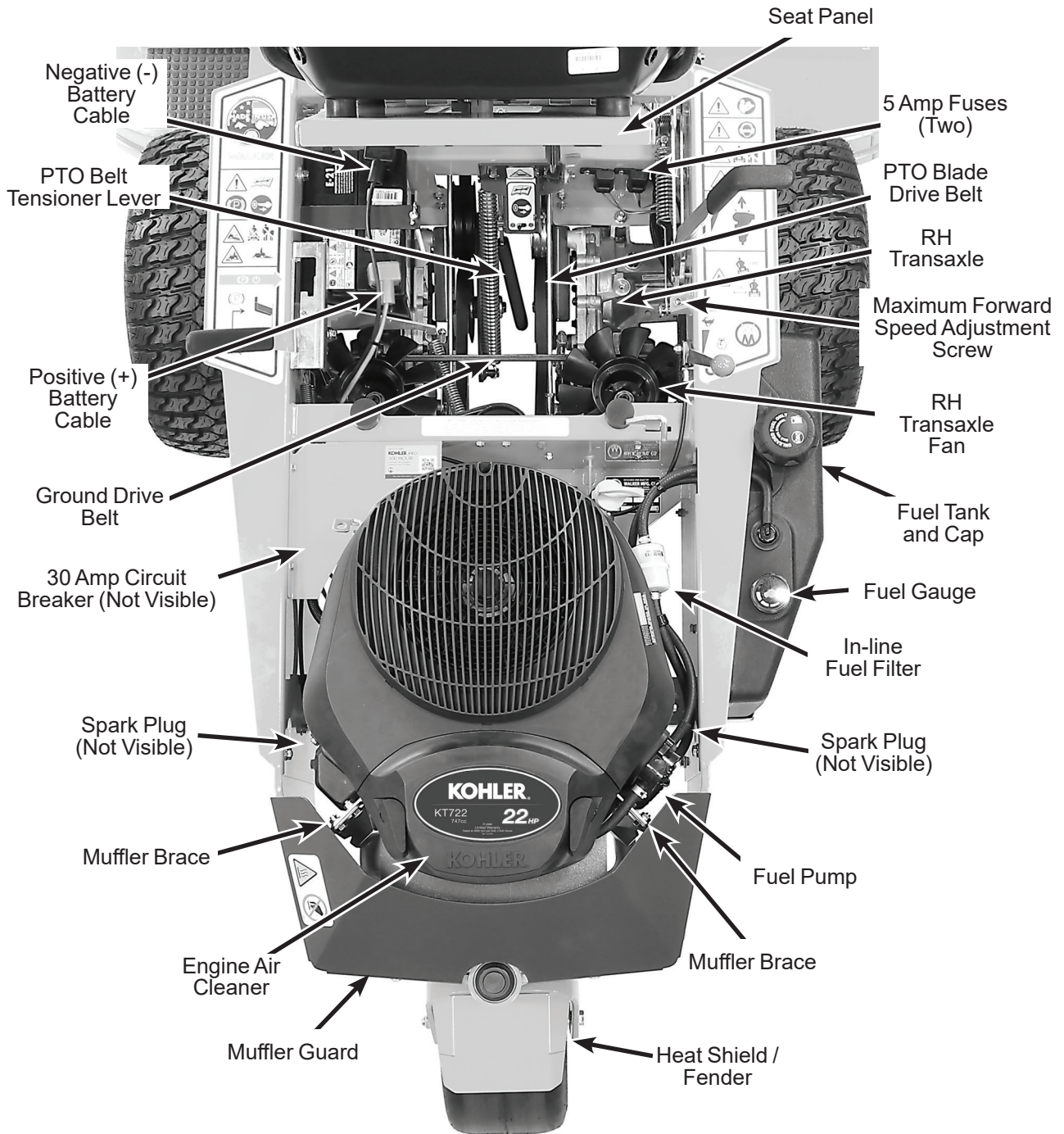

Top View (Engine Compartment)

# Safety Instructions

## In This Section...

Safety Before Operating.....	10
Safety During Operation.....	11
Safety During Maintenance.....	13
Safety, Control, and Instruction Decals.....	14

The Walker Rider Lawnmower has been designed with many safety features to protect the operator from personal harm or injury. However, it is necessary for the operator to use safe operating procedures at all times.

If you have any questions concerning setup, operation, maintenance, or safety, please contact your authorized Walker Mower dealer or call Walker Manufacturing Company at (970) 221-5614.



### CAUTION

Failure to follow safety instructions contained in this manual may result in personal injury or damage to equipment or property.

## Safety Before Operating

- **Read and understand the contents of this Operator's Manual and the machines safety decals before starting and operating the machine.** Become thoroughly familiar with all machine controls and how to stop the machine and disengage the controls quickly. Replacement Operator's Manuals are available for download at <https://www.walker.com>.
- **Never allow children to operate rider mower.** Do not allow adults to operate without proper instruction.
- **Clear the area to be mowed of any foreign objects** which may be picked up and thrown by cutter blades. Pick up all sticks, stones, wire, and any other debris.
- **Do not mow with bystanders in the area.** Keep everyone, especially children and pets, a safe distance away from the area being mowed.
- **Always wear substantial protective footwear.** Do not operate the machine barefoot or wearing sandals, sneakers, tennis shoes, or similar lightweight footwear.
- **Always wear adequate protective clothing and safety gear.** Do not wear loose fitting clothing that could get caught in moving parts. Do not operate this machine while wearing shorts; always wear long pants. Always wear safety goggles or safety glasses when operating this mower. Wearing safety shoes and a helmet is advisable and required by some local ordinances and insurance regulations.
- **Operator hearing protection is recommended.** Prolonged exposure to loud noise can cause impairment or loss of hearing. Wear a suitable hearing protective device, such as earmuffs or earplugs.
- **Do not wear headphones or listen to music while mowing.** Safe operation of the mower requires you to give full attention and to be able to hear clearly.
- **Keep all protective shields and safety devices in place.** If a protective shield, safety device, or decal is damaged, unusable, or missing, repair or replace it **before** operating the machine.
- **Do not operate the mower if you are fatigued, sick or under the influence of alcohol or drugs.**

- **Operators of advanced age are more likely to be involved in a mowing related accident.** Please evaluate the abilities of each operator to make sure they can safely perform the duties required with running this machine.
- **Do not operate the machine without the safety switches functioning properly.** These switches are designed to keep the operator safe. Regularly check to ensure the switches are operating as designed. This information is provided in the Maintenance section "Check Safety Switch System" on page 41. If a safety switch is not functioning properly, do not use the mower until it can be repaired by a Walker Dealer.

 **DANGER**

Handle gasoline with care. Gasoline is highly flammable and its vapors are explosive. Use safe refueling procedures:

- DO NOT fill fuel tank with the engine running.
  - If the engine is hot, allow to cool before refueling.
  - Use an approved fuel container.
  - Fuel the mower outdoors.
  - DO NOT smoke while refueling. Keep matches, cigarettes, cigars, pipes, open flames, or sparks away from the fuel tank and fuel container.
  - Avoid spilling fuel; use a funnel or spout.
  - DO NOT overfill the fuel tank; fill up to the bottom of the fill tube.
- The electrical system battery contains sulfuric acid. Avoid any contact with skin, eyes, and clothing. Keep the battery and acid out of reach of children.

 **WARNING**

This product can expose you to chemicals including Di-(2-ethylhexyl) phthalate which is known to the State of California to cause cancer, and Di-(2-ethylhexyl) phthalate, which is known to the State of California to cause birth defects or other reproductive harm. For more information go to [www.P65Warnings.ca.gov](http://www.P65Warnings.ca.gov).

## Safety During Operation

- **Operate the mower only in daylight** or in good artificial light with good visibility of the area being mowed.
- **Sit on the seat when starting the engine and operating the machine.** Keep feet on the deck footrests at all times when the tractor is moving and/or mower blades are operating.
- **Never operate the tractor without a deck or implement installed.**
- **For a beginning operator, learn to steer (maneuver) the tractor with a slow engine speed before attempting any mowing operation.** Be aware that, with the front mounted mower configuration, the back of the tractor swings to the outside during turns.
- **For an emergency stop:** remember the forward motion of the tractor can always be stopped by pulling the Forward Speed Control (FSC) into the **NEUTRAL-PARK** position.

**NOTE:** The emergency stop procedure is exactly the same procedure as used to normally stop and park the machine.

- **In the event that you lose control of the machine** (such as the transmission drive belt breaks during operation, and the machine starts to freewheel down a slope), you can maintain control by immediately (1) Releasing the steering levers and simultaneously (2) Moving the FSC to the **NEUTRAL-PARK** position. When the machine is stopped or moving slowly, engage the parking brake.

- **Never attempt to disable or mow without the safety switches functioning properly.** These switches are designed to keep the operator safe. Regularly check to ensure the switches are operating as designed. This information is provided in the Maintenance section “Check Safety Switch System” on page 41. If a safety switch is not functioning properly, do not use the mower until it can be repaired by a Walker Dealer.
- **Do not run the engine in a confined area without adequate ventilation.** Exhaust fumes are hazardous and can be deadly.
- **Do not carry passengers** - maximum seating capacity is one (1) person.
- **Watch for holes, rocks, and roots in the terrain and for other hidden hazards.** When mowing tall grass, mow higher than desired to expose any hidden obstacles. Then, clean the area and mow to the desired height.
- **Avoid sudden starts or stops.**
- **Before backing the machine up, look to the rear to be sure no one is behind the machine.** Watch carefully for traffic when crossing or working near roadways.
- **When moving forward, do not suddenly put the tractor in reverse by rapidly pulling on the steering levers,** especially when going downhill, as this can lift the tractor tail wheel off the ground and set up a bucking motion due to operator overcontrol. If bucking does occur, immediately stop the bucking action by pulling the Forward Speed Control (FSC) lever into the **NEUTRAL-PARK** position.
- **Disengage the blade drive when transporting the machine across drives, sidewalks, etc.**
- **Never attempt to make any adjustments while the engine is running,** except where specifically instructed to do so.
- **Never raise the mower deck while blades are rotating.**



**DANGER**

Do not mow or dump grass within 5 feet (1.5 meters) of an embankment, retaining wall with drop off, drainage ditch, water, or other hazard.

- **The maximum recommended slope operating angle is 15 degrees or 27% grade.** When operating the machine on a slope:
  - Reduce speed and use caution to start, stop, and maneuver.
  - Avoid sharp turns or sudden changes in direction to prevent tipping or loss of control of the machine.
  - Do not operate the machine on a slope greater than 15 degrees.



**DANGER**

Do not mow around overhanging tree branches or bushes at the same height as the operator’s torso and head where inadvertent contact may cause injury.

- **Never adjust cutting height with the engine running.** Before adjusting cutting height or servicing, disengage the blade clutch (PTO), engage parking brake, stop the engine, and remove the ignition key. Wait for all movement to stop before getting off the seat.
 

**NOTE:** A blade brake should normally stop drive line rotation within five (5) seconds of disengaging the PTO clutch.
- **Do not operate the mower with the grass deflector shield removed from the deck.** Keep the deflector shield in the lowest possible position when mowing.
- **Do not move tractor with the deck in tilt-up position.**



- **In case of a clogged or plugged mower deck:**
  1. Disengage the blade clutch (PTO), engage the parking brake, and turn the engine off and remove the ignition key before leaving the seat.
  2. Listen to make sure all moving parts have stopped before attempting to lift and visually inspect the deck.
  3. Never place hands under the deck. Use a stick or similar tool to remove clogged material.
- **If the cutting blades strike a solid object or the machine begins to vibrate abnormally,** immediately disengage the blade clutch (PTO), stop the engine, and wait for all moving parts to stop. To prevent accidental starting, disconnect the spark plug wires. Thoroughly inspect the mower and repair any damage before restarting the engine and operating the mower. Make sure cutter blades are in good condition and blade bolts are torqued to 70 lb·ft (95 N·m).
- **Do not touch the engine or muffler while the engine is running or immediately after stopping the engine.** These areas may be hot enough to cause serious burns.
- **Do not stop or park in or near dry grasses or bushes when operating the mower.** The heat from the engine or muffler could ignite the dry material.
- **When leaving the machine unattended, disengage the blade clutch (PTO), engage parking brake, stop the engine, and remove the ignition key.**
- **When using a ramp to load or unload the mower, use extreme caution.** Avoid sudden acceleration and do not exceed a 15 degree angle incline.
- **Only use a full-width ramp** which helps prevent the mower from tipping and reduces the risk of a wheel going off the ramp. Do not use an individual ramps for each side of the mower.

- When equipped with a factory authorized hitch kit, **do not exceed recommended tow capacities.** Do not tow with the PTO clutch or mower blades engaged, and **do not allow people to ride in or on towed trailers.**
- Use caution when towing on slopes, rough terrain or when conditions limit traction. **Do not tow on slopes greater than 5 degrees (9%).**

## Safety During Maintenance

- **To prevent accidental starting of the engine when servicing or adjusting the machine,** remove the key from the ignition switch and disconnect the spark plug wires.
  - **Keep the engine free of grass, leaves, excessive grease, and dirt to reduce fire hazards.**
  - **Keep all nuts, bolts, and screws tight to ensure the machine is in a safe, working condition.** Check the blade mounting bolts frequently, making sure they are tight.
  - **Perform only maintenance instructions described in this manual.** Unauthorized maintenance operations or machine modifications may result in unsafe operating conditions.
  - **If the engine must be running to perform a maintenance adjustment, keep hands, feet, and clothing away from moving parts.** Do not wear jewelry or loose clothing.
  - **Always use the proper engine service manual when working on the engine.** Unauthorized maintenance operations or modifications to the engine may result in unsafe operating conditions.
- IMPORTANT:** Altering the equipment or engine in any manner which adversely affects its operation, performance, durability, or use will **VOID the warranty** and may cause hazardous conditions.
- **Never attempt to disconnect any safety devices or defeat the purpose of these safety devices.**

- **Do not change the engine governor settings or overspeed the engine.** The governor has been factory-set for maximum-safe engine operating speed.
- **Use genuine factory replacement parts.** Substitute parts may result in product malfunction and possible injury to the operator and/or others.
- **Use care when charging the battery** or performing maintenance on the battery and electrical system:
  - Make sure the battery charger is unplugged before connecting or disconnecting cables to the battery.
  - Charge the battery in a well-ventilated space, so gases produced while charging can dissipate.
  - Keep sparks, flames, and smoking materials away from the battery at all times. To avoid sparks, use care when removing battery cables from posts.
  - Disconnect both battery cables before unplugging any wiring connectors or making repairs on the electrical system.

**IMPORTANT:** Keep all applicable manuals immediately accessible to anyone who may operate or service this machine.

### Safety, Control, and Instruction Decals

Safety, control, and instruction decals are installed on the machine. They provide key information to assist the operator with safely using the machine.

 <b>WARNING</b>
<p>If any decals are missing, illegible, or damaged, a replacement should be ordered and installed before operating the machine. The decal part numbers are provided below and in the Parts Manual.</p>

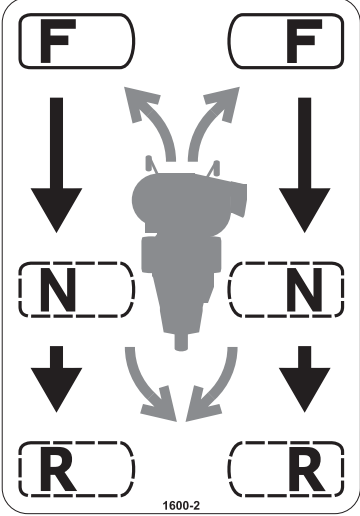
	
<p><b>Location: Between Steering Levers</b> <b>Part Number: 1600-2</b></p>	
<p>Pull Steering Levers back to control direction of tractor movement.</p>	

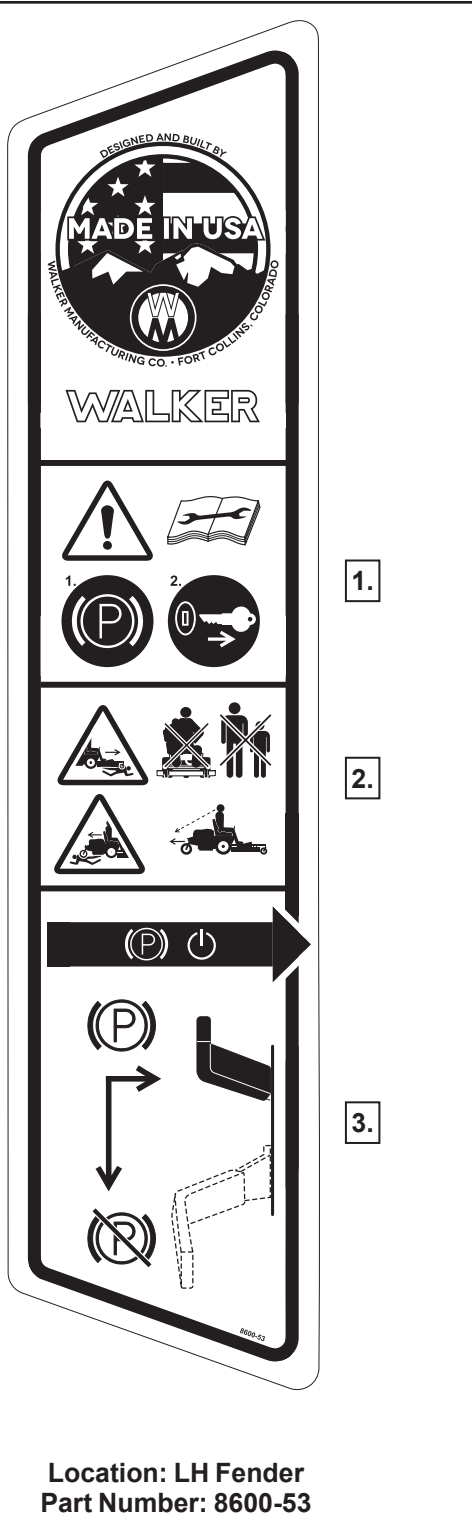

- Part Number: 8600-53 (Continued)**
1. **Warning – read Operator’s Manual before servicing or performing maintenance.**
    - Engage parking brake.
    - Remove ignition key.
  2. **Warning – Crushing/dismemberment hazard of bystanders.**
    - Do not carry passengers. Always stop machine if someone enters the area.
    - Always be aware of what is behind the machine before backing up. Do not mow in reverse unless absolutely necessary. Always look down and behind before and while backing up.
  3. **Parking Brake –**  
Must be engaged to start the engine. Move the lever forward and to the right to engage.

PN: 6895-103

Service with  
**KOHLER PRO**  
**300 HOUR**  
Extended Life Synthetic  
Engine Oil and Oil Filter



 **WALKER**

See more information [wlk.co/kohler-service](http://wlk.co/kohler-service)

**Location: Solenoid Guard**  
**Part Number: 6895-103**

Change engine oil and oil filter every 300 hours.

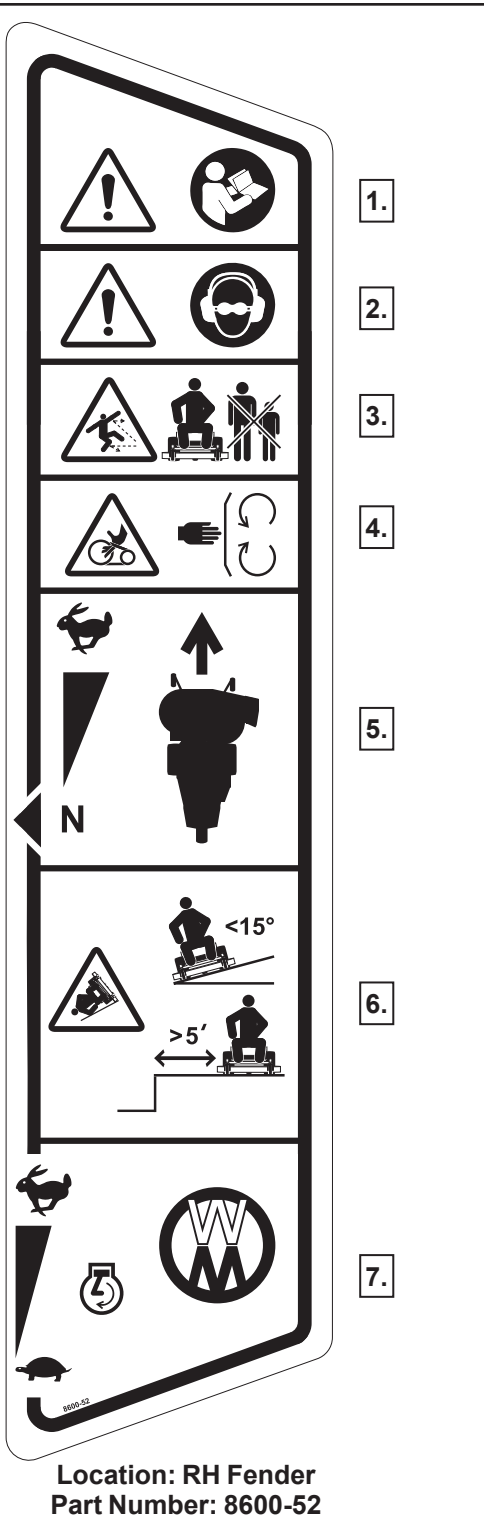

- Part Number: 8600-52 (Continued)**
- Warning – read Operator’s Manual before operating the machine.**
  - Warning – wear eye and ear protection when operating the machine.**
  - Warning – thrown object hazard.**  
Keep bystanders away from the machine when operating.
  - Warning – entanglement hazard.**  
Keep all guards in place while engine is running.
  - Forward Speed Control**  
Move lever forward to increase speed; back to stop.
  - Warning – roll-over hazard.**  
Do not operate on slopes greater than 15 degrees. Mow a safe distance of 5 feet (1.5 m) away from drop-offs or other hazards.
  - Throttle**  
Move lever forward to increase engine speed; back to idle.

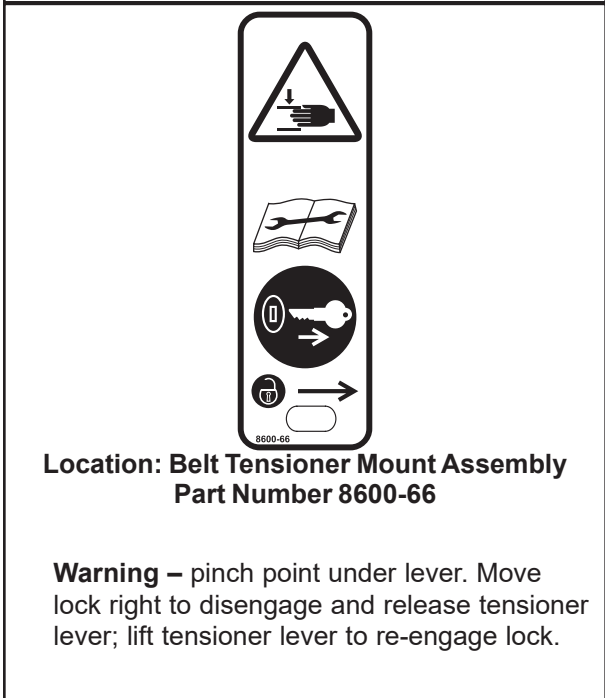



**Location: Deck Carrier Frame**  
**Part Number: 8600-14**

**Warning** – do not operate the machine with the deck tilted up.



**Location: Drive Belt Guard of Mower Deck**  
**Part Number: 8600-55**

**Warning** – entanglement and cutting/dis-  
memberment hazards.

Keep away from pulleys, belts, and other  
components.

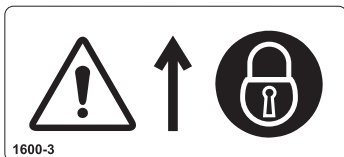

**Location: Deck Carrier Frame**  
**Part Number: 1600-3**

**Warning** – lock deck tilt-up hinge before  
operating the machine.

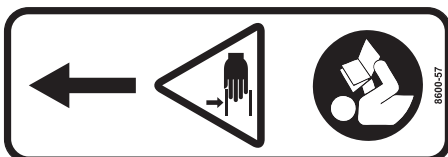

**Location: Deck Carrier Frame**  
**Part Number: 8600-57**

**Warning** – pinch point under the lever.



**Location: Deck Discharge Shield**  
**Part Number: 5848-3**

**Warning** – thrown object hazard.

- Always keep the discharge shield in the  
lowest position when operating.
- Do not remove the discharge shield.

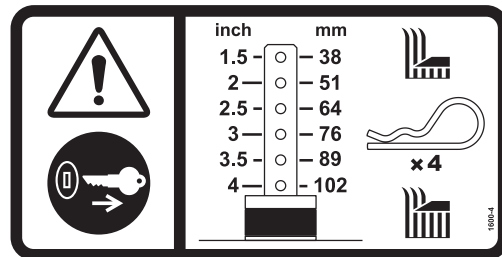

**Location: Deck Belt Cover**  
**Part Number: 1600-4**

**Warning** – stop engine and remove ignition  
key before adjusting deck cutting height.

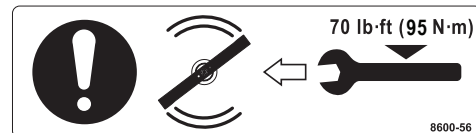

**Location: Carrier Frame**  
**Part Number: 8600-56**

Tighten blade mounting bolt to 70 lb-ft  
(95 N·m).



**Location: Rear Body Near Muffler Tailpipe**  
**Part Number: 8600-5**

**Warning** – hot surface, do not touch.



**Location: Each End of Mower Deck**  
**Part Number: 8600-28**

1. **Warning** – thrown object hazard.
  - ❑ Keep bystanders away from the machine when operating.
  - ❑ Clear lawn of debris before operating.
  - ❑ Keep any discharge deflector in place and in the lowest position.
2. **Warning** – rotating mower blades are a cutting/dismemberment hazard to hands and feet.
  - ❑ Keep all body parts away from rotating mower blades.
  - ❑ Do not step on end of deck.



**Location: Side of Engine**  
**Part Number: 8600-12**

- Warning** – carbon monoxide (CO) poisoning hazard.
- ❑ CO emitted by a running engine can be deadly.
  - ❑ Do not operate indoors or in other enclosed areas.

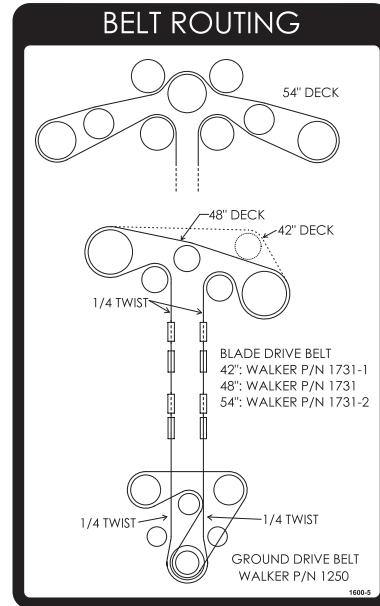

**Location: Seat Panel (Underside)**  
**Part Number: 1600-5**

1. Blade Drive Belt routing
2. Ground Drive Belt routing

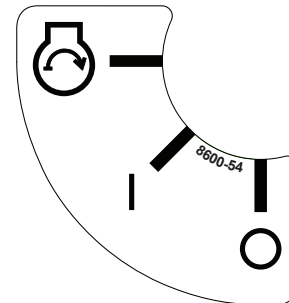

**Location: Ignition Switch**  
**Part Number: 8600-54**

Ignition switch positions: "O" for OFF, "I" for ON (RUN), and  for START

**IMPORTANT - ENGINE COOLING SYSTEM MAINTENANCE**  
CHECK AND CLEAN ENGINE ROTATING INLET SCREEN AND STATIC SCREEN GUARD DAILY (EVERY 8 HOURS) OR MORE OFTEN IN DIRTY CONDITIONS. CYLINDER HEAD COOLING FINS SHOULD BE CHECKED AND CLEANED BY REMOVING ENGINE SHROUD EVERY 100 HOURS. 8605

**Location: Chassis Crossmember**  
**in Front of Engine**  
**Part Number: 5855**

# Operating Instructions

## In This Section...

Operator Controls.....	19
Pre-Operation Checklist .....	24
Starting the Engine.....	25
Adjusting Ground Speed and Steering.....	25
Engaging the Blades .....	27
Stopping the Machine.....	28
Adjusting the Cutting Height.....	29
Deck Tilt-Up Position.....	29
Recommendations for Mowing.....	30
Transaxle Lockout .....	32
Recommendations for Towing.....	33
Recommendations for Tilt-up Deck Operation and Transport.....	33

## Operator Controls

---

This section covers the location and function of the following operator controls.

- “Ignition Switch” on this page
- “Engine Throttle” on page 20
- “Steering Levers” on page 20
- “Forward Speed Control (FSC)” on page 22
- “Blade Clutch Switch (PTO)” on page 22
- “Parking Brake” on page 22
- “Circuit Breaker” on page 22
- “Seat Panel Latch” on page 23
- “Hourmeter” on page 23
- “Transaxle Lockout Arms” on page 23

### **CAUTION**

Before operating the mower, become familiar with the location and function of all operator controls. Knowing the location, function, and operation of these controls is important for safe and efficient operation of the mower.

### Ignition Switch

The ignition switch is located on the right front of the body and is used to start and stop the engine. The switch has three positions:

- “O” is the **OFF** position
- “I” is the **ON (RUN)** position
-  is the **START** position

When starting the engine, turn the key clockwise to the **START** position. Do not hold the key in this position longer than 10 seconds. If the engine does not start, return the key to the **OFF** position for at least 60 seconds before making a restart attempt.

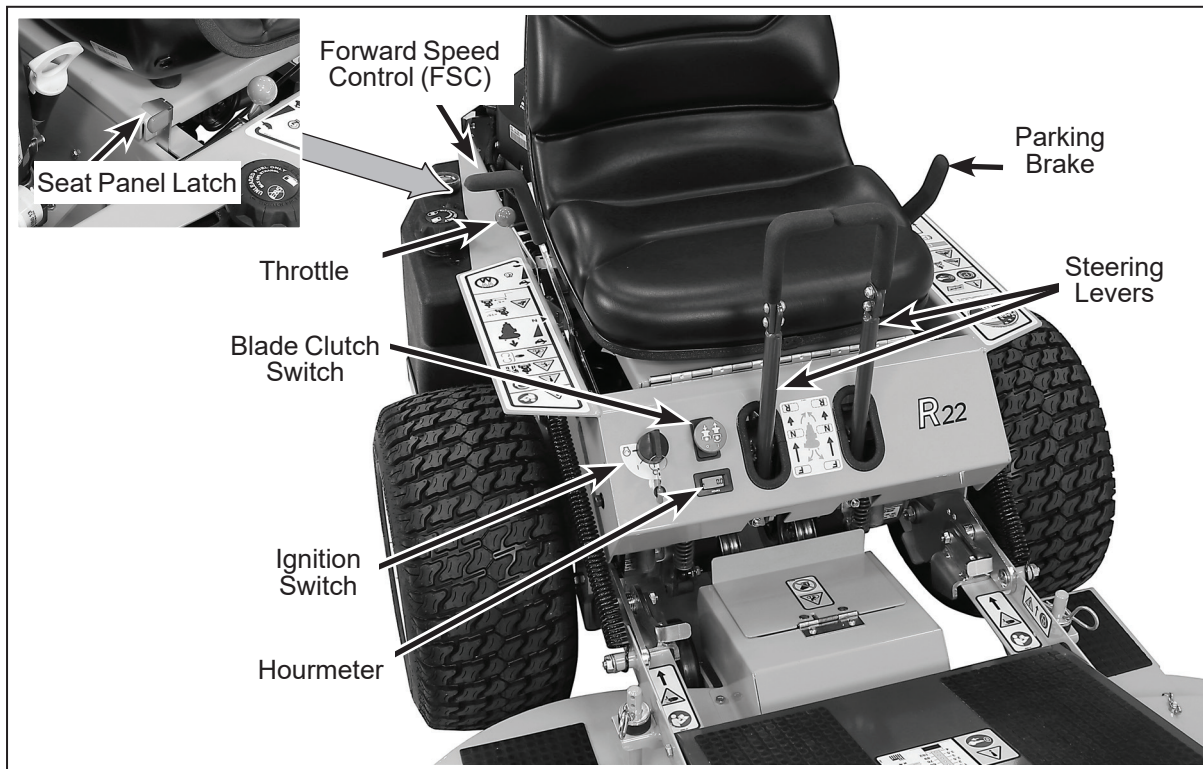

**Operator Controls**

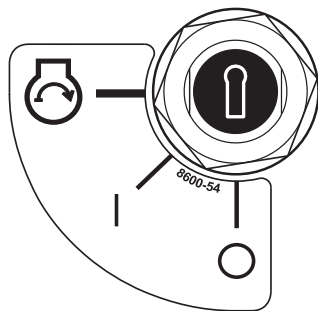

**Ignition Switch**

**IMPORTANT:** Prolonged cranking can damage the starter motor and shorten battery life.

Release the key when the engine starts, and it will return to the **ON (RUN)** position. To stop the engine, rotate the key counterclockwise to the **OFF** position.

**Engine Throttle**

The throttle control lever (red knob) is located on the right side of the seat behind the FSC lever and is used to control engine speed. Moving the lever forward toward the **FAST** position increases en-

gine speed; moving it backward toward the **IDLE** position decreases engine speed.

**Steering Levers**

Each drive wheel is controlled by its own independent steering lever, for both steering function and for forward or reverse motion.

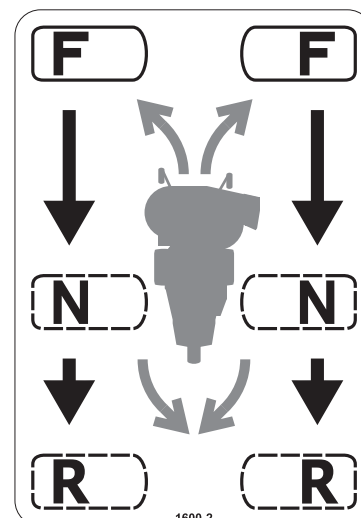

**Steering Lever Decal**



The Forward Speed Control (FSC) lever sets the maximum forward speed, and also sets the forward position of the steering levers.

The steering levers operate **only with a backward pulling movement** of the lever, which causes the drive wheel for that lever to first slow down, stop, and then reverse with a full backward lever stroke. The levers are released to the **FORWARD** position for “straight-ahead” ground travel.

**NOTE:** Pushing forward on the steering levers will not cause any change in tractor motion - there will be no steering lever reaction and there will be no machine damage.

The Forward Speed Control also establishes the NEUTRAL-PARK position of the steering levers.

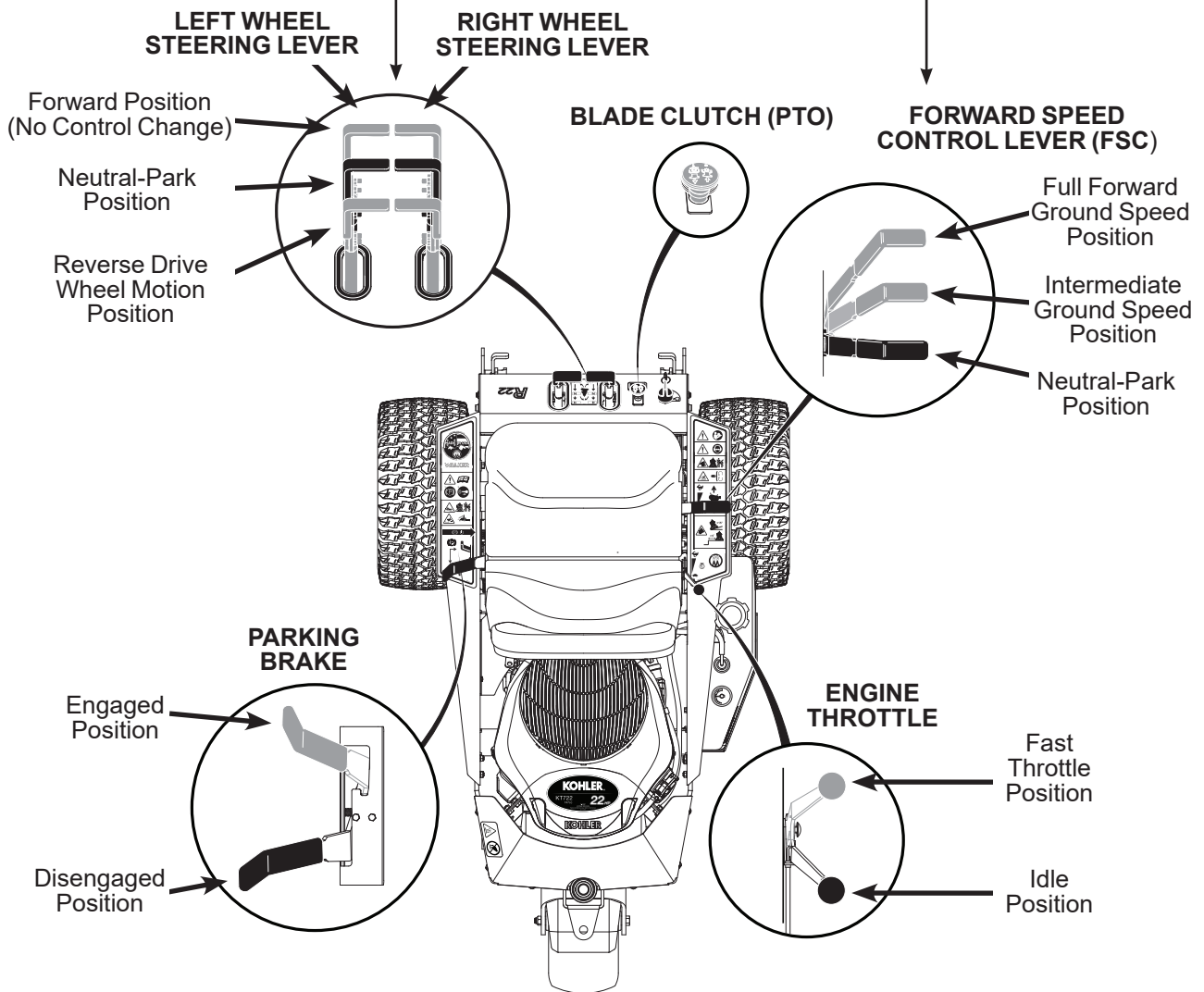

Operating Controls (Top View from Drivers Point of View)

### Forward Speed Control (FSC)

Forward Speed Control (FSC) has two functions: One is to set forward travel speed, and the other is to establish the **NEUTRAL-PARK** position. When the FSC lever is moved into the **FORWARD** position, a friction lock holds any forward speed setting from 0 to 6 mph (0 to 10 km/h).

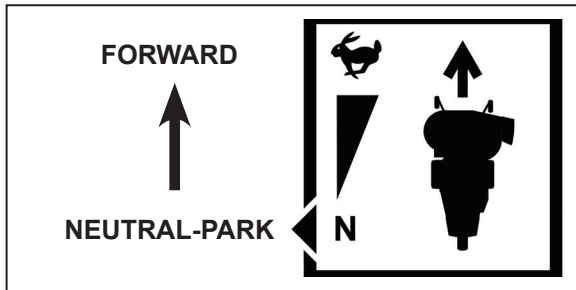

Forward Speed Control FSC

The ground speed is proportional to the lever position; the further the lever is advanced forward, the faster the tractor moves. It is not necessary to hold the FSC in position since the friction lock maintains the selected lever position.

Pulling back on the steering levers overrides the FSC setting and slows or stops forward travel. Releasing the steering levers allows the tractor to resume forward travel at the speed set by the FSC lever. To stop and park the machine, the FSC lever is moved backward to the **NEUTRAL-PARK** position.

### Blade Clutch Switch (PTO)

The blade clutch switch (red button) is located beside the steering levers. It is used to engage and disengage the mower blades. The blade clutch switch has two positions. Pull out the switch to engage the PTO that drives the blades and push down the switch to disengage the PTO and engage the blade brake.

### Parking Brake

The parking brake uses a positive mechanical lock similar to the Park position on an automotive automatic transmission. The brake rests in a forward notch in the body panel when it is engaged. Push the lever to the left and then back to release the brake.

**IMPORTANT:** Stop the tractor completely before engaging the parking brake. If the tractor is moving when the brake is engaged, it will result in sudden stoppage and possible internal damage to the transaxle.

**NOTE:** If pressure on the parking brake (e.g., parked on a hill) makes it impossible to release the parking brake with the parking brake lever, move the mower gently forward or backward to allow the brake detent to release.



Parking Brake Engaged

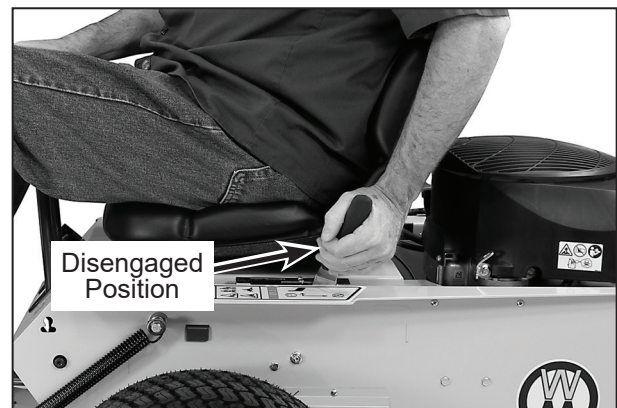

Parking Brake Disengaged

### Circuit Breaker

The auto reset 30 amp master circuit breaker is located in the rear left of the chassis and protects the electrical system. In addition, there are two (2) 5-amp fuses located on the chassis to the right of the PTO belt tensioner lever that provide protection to the safety circuits.

### Seat Panel Latch

The seat hinges forward for maintenance access and is latched down in the normal operating position. To raise the seat panel, disengage the latch and lift the seat.

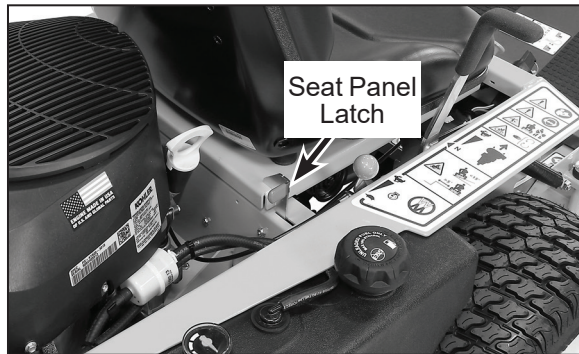

Seat Panel Latch

### Hourmeter

The hourmeter, which is located on the right front of the body, displays operating time accumulated when the PTO (blade drive) clutch is engaged.

The hourmeter **does not have a manual reset function.**

**NOTE:** The blinking hour glass on the display means that the meter is operating properly.

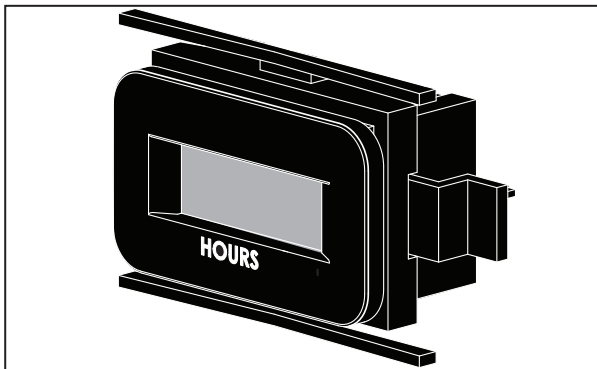

Hourmeter

### Transaxle Lockout Arms

The transaxle lockout arms disengage the transaxles to permit freewheeling the tractor. This is used to enable moving the machine without the engine running (e.g., for service). There are two lockout arm tabs, one for each transaxle, used to engaged and disengaged the lockout feature. More infor-

mation about this feature is covered in "Transaxle Lockout" on page 32.



LH Transaxle Lockout Arm Tab

**NOTE:** The transaxle lockout arm tabs should be completely retracted against the chassis during normal use, otherwise operation of the transaxle may be erratic.

**IMPORTANT: DO NOT TOW** this mower faster than 2 mph (3.2 km/h) with the transaxle lockout engaged. Towing can produce excessive internal pressure and damage the transaxle(s).

## Pre-Operation Checklist

 **WARNING**

It is critical to follow the steps provided for setup and assembly of the tractor and deck to ensure the safety of the operator and the equipment.

Before operating the mower for the first time, and as a routine before daily operations, it is important to make sure the mower is properly prepared and ready for operation. The following is a list of items to be checked. (For a mower with frequent operation, some of these items will not need to be checked every day, but the operator should be aware of the condition of each.)

**PERFORM ‘EVERY USE’ MAINTENANCE ITEMS**

These items are covered in detail in the Maintenance section that starts on page 34.

‘Every Use’ Maintenance Items include:

- Check Engine Crankcase Oil
- Check/Clean Engine Air Cooling System
- Clean Grass Buildup Under Deck
- Inspect/Service Mower Blades
- Check Security of Air Filtration Components
- Check Deck Side Discharge Deflector Shield in Lowest Position

**PERFORM REQUIRED SCHEDULED MAINTENANCE PROCEDURES**

See the “R22 Maintenance Schedule Chart” on page 34 for a complete list of periodic maintenance.

**FILL FUEL TANK**

Fill the fuel tank using clean, fresh **automotive grade unleaded gasoline** (87 octane minimum, 10% ethanol maximum).

**IMPORTANT: DO NOT** permit dirt or other foreign matter to enter the fuel tank. Wipe dirt from around the filler cap before removing. Use a clean fuel storage container and funnel.

**IMPORTANT: DO NOT mix oil with gasoline.** Always use fresh, automotive grade unleaded gasoline. **DO NOT** use gasoline containing greater than 10% ethanol. **DO NOT** use additives, such as carburetor cleaners, deicers, or moisture removing agents. **DO NOT** use gasoline blended with methyl alcohol.

 **DANGER**

Handle gasoline with care. Gasoline is highly flammable and its vapors are explosive. Use safe refueling procedures:

- DO NOT fill fuel tank with the engine running.
- If the engine is hot, allow to cool before refueling.
- Use an approved fuel container.
- Fuel the mower outdoors.
- DO NOT smoke while refueling. Keep matches, cigarettes, cigars, pipes, open flames, or sparks away from the fuel tank and fuel container.
- Avoid spilling fuel; use a funnel or spout.
- DO NOT overfill the fuel tank; fill up to the bottom of the fill tube.

## Starting the Engine

### CAUTION

Before operating the mower, read and understand all Safety Instructions and Operating Instructions.

### WARNING

NEVER run the engine in an enclosed or poorly ventilated area. Engine exhaust contains carbon monoxide, an odorless and deadly gas.

1. Before attempting to start the engine, make sure:
  - The operator is seated.
  - The Forward Speed Control (FSC) is in **NEUTRAL-PARK** position.
  - The parking brake is **ENGAGED**.
  - The blade clutch (PTO) is **DISENGAGED**.
  - The deck hinges are **LOCKED**.
2. Move the throttle 1/4 to 1/2 open (toward **FAST**).
3. Turn the ignition switch to the **START** position to start the engine. Release the key to "**I**" (**RUN**) position as soon as the engine starts.

**IMPORTANT: DO NOT** crank the engine continuously for more than 10 seconds at a time. If the engine does not start, turn the key to the OFF position and allow a 60 second cool-down period between starting attempts. Failure to follow these guidelines can damage the starter motor and shorten battery life. Consult your Walker dealer or authorized Kohler dealer for additional help.

### CAUTION

A safety interlock switch system PREVENTS CRANKING the engine with any one of these three controls in the OPERATING position: (1) Forward Speed Control out of neutral, (2) blade clutch (PTO) engaged, or (3) parking brake disengaged. If the engine cranks otherwise, the safety system is not working and should be repaired or adjusted before operating the mower. The deck hinge lock switch will allow the engine to crank but not start. **DO NOT** disconnect safety switches; they are for the operator's protection.

## Adjusting Ground Speed and Steering

### CAUTION

Learn to START, STOP, and MANEUVER the mower in a large, open area. If the operator has not operated a machine with **lever steering or dual hydrostatic transmissions**, steering and ground operation should be learned and practiced until the operator is completely comfortable handling the machine **BEFORE ATTEMPTING TO MOW**.

### DANGER

Keep feet on footrests at all times when the machine is moving. Never operate the tractor without a deck or implement installed.

1. Sitting on the mower with the engine started, move the FSC out of **NEUTRAL-PARK** position to the desired forward speed. **DO NOT** hold forward on steering levers. It is not necessary to hold the FSC lever in position since a friction lock maintains the selected lever position (and forward travel speed).



**Correct Operator Hand Position**

**NOTE:** If the FSC lever will not stay in the selected position, the friction lock needs to be adjusted. See “Forward Speed Control Friction Adjustment” on page 58 for details.

2. Steer by pulling the lever on the side of desired direction of turn, e.g., pull the **LH** lever to **turn left**. To minimize the possibility of overcontrol, use only one hand on both steering levers.
3. Reverse direction of the mower by pulling back on both levers.

**NOTE:** Smooth action on the steering levers will produce smooth mower operation. Remember to keep the engine and ground speed slow until learning the control response.

4. The FSC may be adjusted forward for faster ground speed and backward for slower ground speed. When mowing, ground speed should be adjusted to match the load on the cutter blades, i.e., as the engine pulls down in heavy cutting, pull back on the FSC lever to reduce ground speed. Adjusting ground speed helps maintain a balance between engine power and blade speed for high-quality cutting action.
5. Stop ground travel by pulling both steering levers backward to the **NEUTRAL** position (tractor not moving) and then moving the FSC lever to the **NEUTRAL-PARK** position.

**NOTE:** If the tractor creeps forward or backward with the FSC lever in the **NEUTRAL-PARK** position, the transmission control needs to be adjusted. See “Neutral Function Adjustment” on page 59 for details.

 **CAUTION**

An operator presence switch (seat switch) will cause the engine to stop if the parking brake is in the **DISENGAGED** position and/or the FSC is out of the **NEUTRAL-PARK** position (tractor stationary or moving forward) and the operator is not in the seat. The function of this switch should be checked by the operator raising off the seat, first with the parking brake **DISENGAGED**, and then with the tractor moving forward; the engine should stop. In each case, if the safety system is not working, it should be repaired or replaced before operating the mower. **DO NOT disconnect the safety switches; they are for the operator’s protection.**

 **WARNING**

When moving forward, **DO NOT** suddenly put the tractor in reverse by rapidly pulling on the steering levers, especially when going downhill, as this can lift the tractor tail wheel off the ground and set up a bucking motion due to operator overcontrol. If bucking does occur, immediately stop the bucking action by pulling the Forward Speed Control (FSC) lever into the **NEUTRAL-PARK** position.

### Recommendations for Getting Started:

- Learn operation of the mower in an open area away from buildings, fences, and obstructions. Learn operation on flat ground **BEFORE** operating on slopes.
- Start maneuvering the mower with SLOW engine speed and SLOW Forward Speed Control setting until familiar with all operating characteristics.

**NOTE:** Once you are familiar with the operating characteristics, the engine should not be run at slow speeds. The mower is designed to be operated at full throttle for maximum cutting power and component longevity.

- Remember it is not necessary to hold the steering levers forward (a unique Walker feature); always **PULL** on the levers for steering or for reverse motion of the mower.
- Learn to operate the mower with your left hand on the steering levers and right hand on Forward Speed Control. The use of two hands on the steering levers tends to cause overcontrol.
- Learn to operate the steering levers with smooth action. Jerky movements are hard on the transmission and lawn. For sharp turns, do not allow the inside wheel to stop and twist on the grass. Pull the steering lever controlling the inside wheel into reverse for a smooth “rolling” turn (one wheel rolling forward while the other rolls backward).
- Practice maneuvering the mower until you can make it go exactly where you are aiming.
- Remember, for an emergency stop, or in case of loss of control, machine movement can always be stopped quickly by pulling the Forward Speed Control into the **NEUTRAL-PARK** position.

### **WARNING**

If the transmission drive belt breaks during operation, and if the machine is on a slope, the machine will freewheel down the slope. To maintain control, immediately:

1. Release the steering levers and simultaneously
2. Move the FSC to the **NEUTRAL-PARK** position.

When the machine is stopped or moving slowly, engage the parking brake.

**NOTE:** The emergency stop procedure is exactly the same procedure as used to normally stop and park the machine.

### Engaging the Blades

1. Set the engine throttle fast enough to prevent the engine from stalling which should be about 1/3 speed. **Do not attempt to engage the blade clutch at high engine speeds.** This will drastically shorten drive belt life. Use only moderate engine speed when engaging the blade clutch.
2. Engage the blade clutch by pulling out on the blade clutch switch.



**Blade Clutch Engaged**

3. To disengage the blades, reduce the throttle to half speed or less and push in the blade clutch switch.

**IMPORTANT: DO NOT** engage the blade clutch when transporting the mower across drives, sidewalks, loose materials, etc.

**IMPORTANT: DO NOT** engage the blade clutch if the deck is not installed on the tractor.

 **CAUTION**

An operator presence switch (seat switch) will cause the engine to stop if the blade clutch is engaged and the operator is not in the seat. The function of this safety switch should be checked by the operator raising off the seat and engaging the blade clutch; the engine should stop. If the switch is not working, it should be repaired or replaced before operating the mower. **DO NOT** disconnect the safety switches; they are for the operator's protection.

 **CAUTION**

If the cutting blades strike a stationary object while mowing, stop the mower immediately, remove the key, lift the deck, and inspect the deck and blades thoroughly for damage. Also, make sure the blade retaining bolts are still torqued to 70 lb·ft (95 N·m).

 **WARNING**

A brake stops the cutter blades from free-wheeling within five (5) seconds after disengaging the clutch. If the brake system malfunctions and the blades do not stop within five (5) seconds, the brake should be repaired or replaced before further operation of the mower. Contact your Walker dealer for service.

## Stopping the Machine

---

1. Pull the steering levers to the **NEUTRAL** position and then move the FSC lever to the **NEUTRAL-PARK** position.
2. Slow the engine to a fast idle; put the throttle in the 1/2 throttle position.
3. Disengage the blade clutch.

**IMPORTANT: DO NOT** disengage the blade clutch with high engine speed (above 1/2 throttle) since the brake action on the blade drive will cause premature wear of the brake element.

4. Turn the ignition switch to **OFF**. When stopping the engine, do not reduce the throttle below 1/2 speed. Since the engine is equipped with a fuel shutoff solenoid, stopping at low idle may cause engine run-on or backfiring.
5. Engage the parking brake by moving the lever forward and to the right.

**IMPORTANT:** It is recommended to always engage the parking brake when turning off the mower. The mower should not roll freely when the engine is stopped, but if the mower is parked on a slope, it is possible it will creep especially if the transmission is warm from operation.

 **WARNING**

Remove the key from the ignition switch when leaving the mower unattended. This will prevent children and inexperienced operators from starting the engine.



## Adjusting the Cutting Height

Cutting height is adjusted by positioning the four (4) retainer hitch pins in a series of six vertical holes on the deck support pins. Lift handles have been provided on each end of the deck to assist in raising the deck while positioning the hitch pins. Cutting heights range from 1.5 in. (38 mm) [top holes] to 4 in. (102 mm) [bottom holes] in 1/2 in. (13 mm) increments.

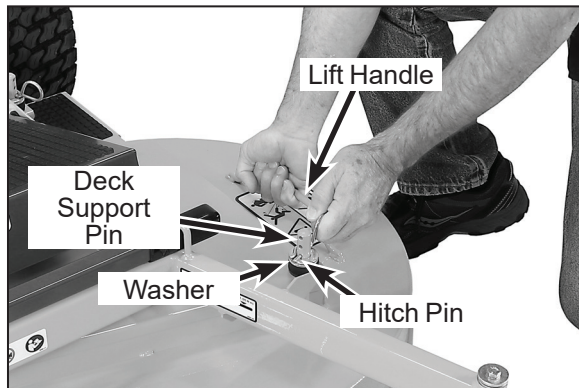

**Cutting Height Adjustment**

### **WARNING**

The engine must be stopped before adjusting cutting height. Disengage the blade clutch (PTO), engage the parking brake, stop the engine, and remove the ignition key. Wait for all movement to stop before getting off the seat.

## Deck Tilt-Up Position

Tilting up the deck is useful to clean under the deck, inspect and replace the blades, and lubricate spindle grease fittings.

### **DANGER**

Before raising the mower deck, always stop the engine and remove the key from the ignition.

1. Stop the engine, and remove the key from the ignition.

2. On each side, push down the deck lock lever to unlock the carrier frame pivot joint. With the lever depressed, push down on the carrier frame, and then release the deck lock lever.

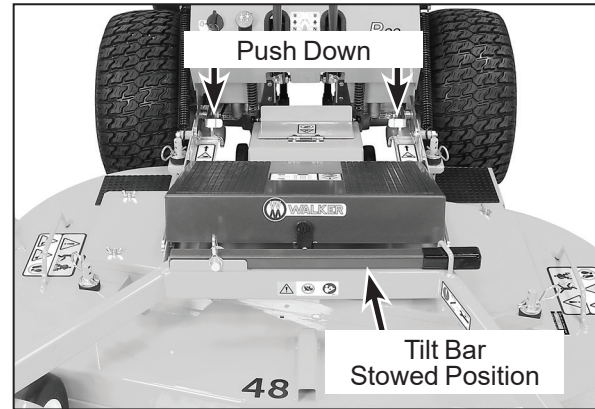

**Deck Lock Lever**

3. Remove the deck tilt bar from its locked storage position along the front of the footrest, and install it in the socket on the front of the deck housing. Secure the bar in position with the hitch pin.

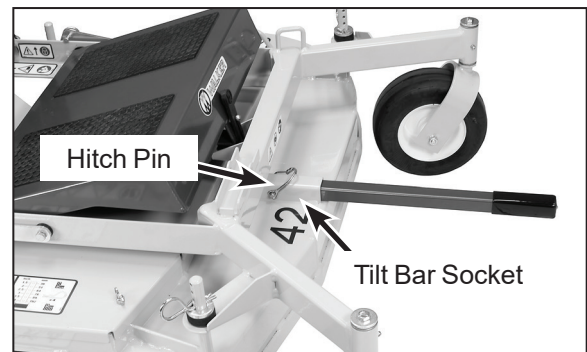

**Tilt Bar Installed**

4. Using the deck tilt bar, raise deck to the tilt-up position and insert the **two (2) tilt-up links** into the lock holes on each side of the tractor body.

### **DANGER**

Do not operate the mower with deck in tilt-up position. Do not move the tractor with the deck in the tilt-up position.

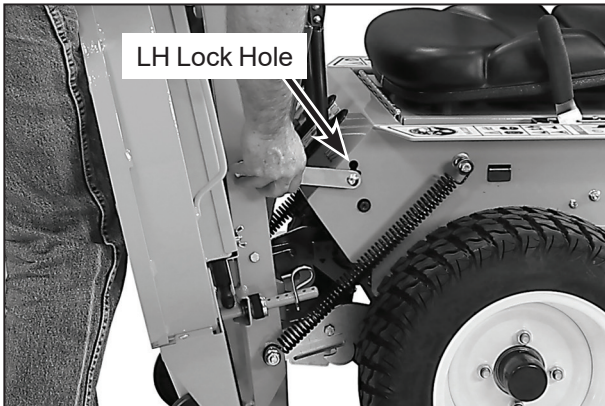

Insert RH and LH Tilt-Up Links into the Lock Holes

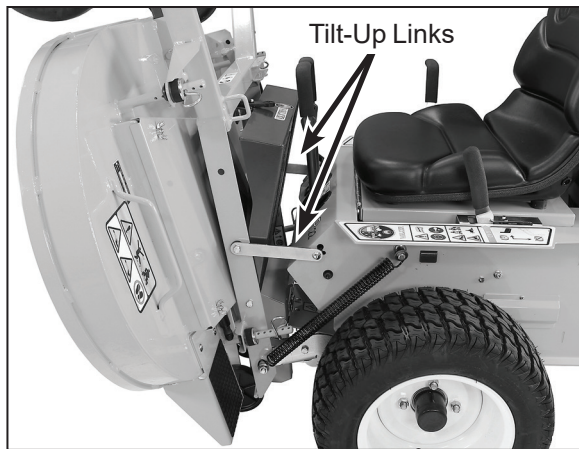

Deck Locked in Tilt-Up Position

- Reverse procedure to lower the deck back to the operating position. One side at a time, hold the lock lever in the down position and simultaneously raise the carrier frame at the pivot joint to re-engage the deck hinge lock.

**CAUTION**

Do not operate the mower with the carrier frame **unlocked**. The frame must be locked before operating the mower. A safety switch prevents the engine from starting with the RH pivot unlocked.

**Recommendations for Mowing**

- Keep the mower deck and discharge shield clean.
- Mow with sharp blades. A dull blade tears the grass (resulting in poor lawn appearance) and uses extra power (slowing the mowing speed).
- It is preferable to cut grass when it is dry and not too tall. Mow frequently and do not cut grass too short. (For best appearance, cut off 1/3 or less of existing grass height.)
- When mowing, operate the engine at **full throttle** for the best cutting action. Mowing with a lower engine RPM causes the mowing blade to not cut clean and tear the grass. The engine is **designed to be operated at full speed**.
- When mowing in adverse conditions (tall and/or wet grass), mow the grass twice. Raise the mower to the highest setting, 4 in. (10 cm), for the first pass and then make a second pass cutting to the desired height.

**IMPORTANT:** Operate the engine at **full throttle** when mowing, to allow the engine to produce full horsepower and to increase efficiency of the engine cooling system.

- Use a **slow** setting on the FSC for **trimming operations**.
- Use an alternating **stripe mowing pattern for best appearance** and vary the direction of the stripe each time the grass is mowed to avoid wear patterns in the grass.
- Make sure the mower is **leveled properly** for a smooth cut. Refer to “Deck Leveling” on page 57.
- The side discharge deflector shield **must not be removed** and must be kept in the lowest possible position to deflect grass clippings and thrown objects downward.
- Orient the side discharge away from sidewalks or streets to minimize cleanup of clippings. When mowing close to obstacles, orient the side discharge away from obstacles to reduce the chance of damage to property by thrown objects.

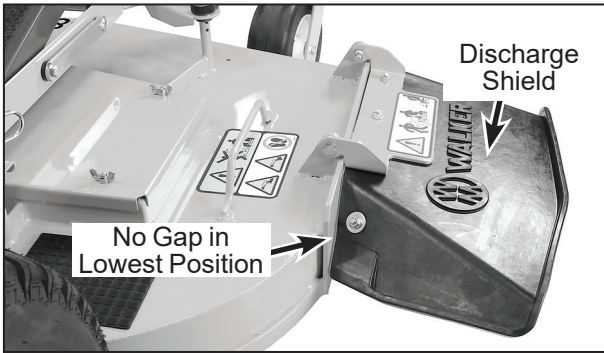

Side Discharge Shield in Lowest Position

- Avoid damage to the grass by slipping and skidding of the drive tires. Use **smooth control movements** of the steering levers since the transaxles are “power boosted controls” and jerking the levers can easily slip the tires. For sharp turns, do not allow the inside wheel to stop and twist on grass; pull inside steering lever into reverse for a smooth “rolling” turn (one wheel rolling forward while the other rolls backward).

**⚠ DANGER**

Do not mow or drive the tractor within 5 feet (1.5 meters) of an embankment or retaining wall with drop off.

- When operating on a slope, **reduce speed and use caution** to start, stop, and maneuver. Avoid sharp turns or sudden changes in direction. The **maximum recommended slope operating angle is 15 degrees or 27% grade.**

**⚠ DANGER**

Do not mow around overhanging tree branches or bushes at the same height as the operator’s torso and head where inadvertent contact may cause injury.

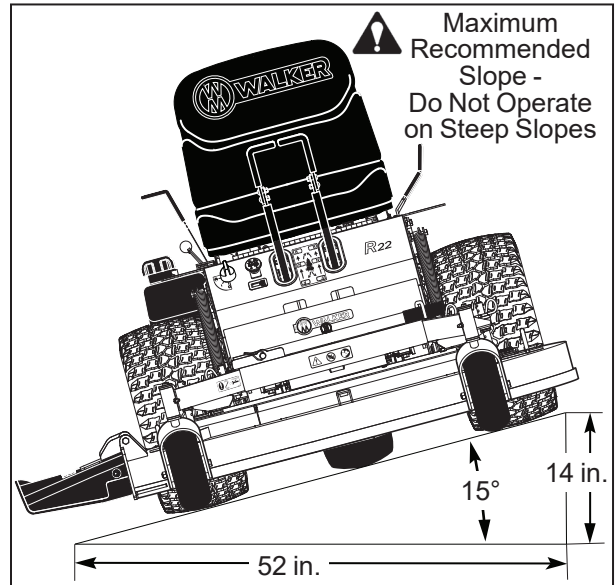

Maximum Recommended Slope

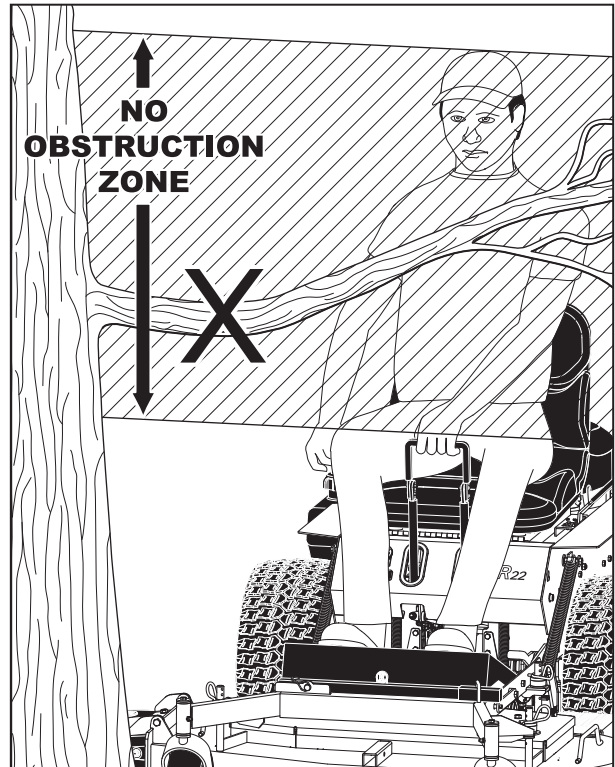

Avoid Low Hanging Branches



No Driving Zone

## Transaxle Lockout

**IMPORTANT: DO NOT TOW** this mower faster than 2 mph (3.2 km/h) with the transaxle lockout engaged. Towing can produce excessive internal pressure and damage the transaxle(s).

Lockout the transaxles to permit freewheeling and to move the tractor with the engine **NOT** running (dead battery, maintenance, etc.).

1. Turn off the engine and remove the key from the ignition.
2. Reach below the chassis behind the seat. Slide the transaxle lockout arm tab back and toward the middle of the machine to catch the step that holds the arm in the **LOCKOUT** position. **Repeat on the other side.**

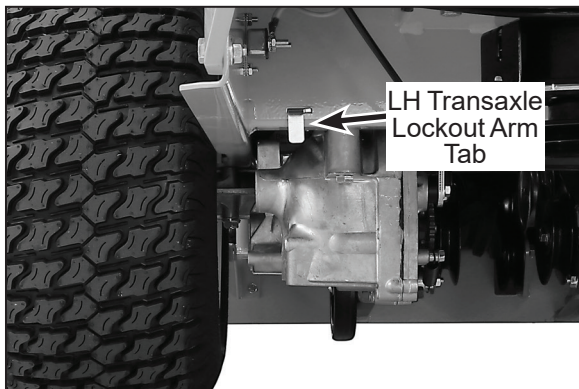

LH Transaxle Lockout Tab  
Shown in Normal OPERATING Position



Engage Transaxle LOCKOUT (LH shown)

The mower will “freewheel” with the arms in the **LOCKOUT** position.

3. After moving the mower, release the lockout arms and return them to normal **OPERATING** position. They should be completely retracted against the chassis, otherwise operation of the transaxle may be erratic.

## Recommendations for Towing

When equipped with a factory authorized hitch kit, the maximum towing capacity on flat ground is 250 lbs (113 kg) gross trailer weight. The maximum tongue weight is 50 lbs (23 kg). **Use caution when towing on slopes, rough terrain or when conditions limit traction.**

- Do not operate on slopes greater than 5 degrees (9%).
- Do not tow with PTO clutch or mower blades engaged.
- Do not allow people to ride in or on towed trailers.

## Recommendations for Tilt-up Deck Operation and Transport

To avoid potential deck and/or tractor damage while using the tilt-up deck, the following recommendations are offered:

- **Do not move the tractor** with the deck in the tilt-up position since both the roller wheels (on the back of the deck) may be damaged by moving the tractor. The tilt-up configuration should only be used when the tractor is parked.
- When transporting a tractor with the deck in the tilt-up position (on a truck or trailer), the **deck should be secured** to the vehicle with a strap or rope (stop vertical movement). This will prevent the deck from bouncing on the rear roller wheels (causing breakage). This will also prevent the deck from unhooking from the tractor and falling, potentially causing deck or tractor damage. Damage to other items parked in front of the deck may also occur.

# Maintenance

## R22 Maintenance Schedule Chart

This section provides the recommended service items and intervals. Regular maintenance is required to keep the mower operating at optimal levels and to prevent damage. Information about each of these tasks is provided in this section, and many of them can be performed by the owner-operator unless otherwise noted. Contact your Walker Dealer if you have questions or need assistance.

Service Item	Each Use	25 Hours	75 Hours	100 Hours	300 Hours	500 Hours	Yearly	Page
Check Engine Crankcase Oil Level	x							35
Check/Clean Engine Air Cooling System	x							36
Clean Grass Buildup Under Deck	x							37
Inspect/Service Mower Blades	x							37
Check Security of Air Filtration Components	x							39
Check Discharge Shield	x							39
Lubricate Grease Fittings and Oil Points*		x						39
Check Tire Pressure		x						41
Check Drive Belts (Ground Drive, Blade)		x						41
Check Safety Switch System		x						41
Clean/Replace Engine Precleaner Air Filter*		x						42
Replace Engine Air Filter*			x					43
Clean Engine Cooling System				x				45
Replace Fuel Filter				x				46
Clean Transaxle Housing and Fans				x				46
Check Drive Tire Mounting Nuts				x				47
Check Blade Brake Function				x				47
Change Engine Crankcase Oil**					x			44
Change Engine Oil Filter***					x			44
Replace Spark Plugs and Set Gap						x		47
Check/Adjust Engine Valve Lash <sup>△</sup>						x		47
Check FSC Friction Lock							x	48
Check Transmission Control Settings							x	48
Check Fuel Lines and Clamps							x	48
Clean Battery Terminals							x	49
Charge Battery (As Required)							x	49
Long-Term Storage Preparation (As Required)							x	50

\* More often in extremely dusty or dirty conditions

\*\* Factory service uses Kohler PRO® oil. If conventional oil is used for oil changes instead of the Kohler PRO®, the oil must be changed every 100 hours.

\*\*\* Factory service uses a Kohler PRO® filter. If a conventional Kohler filter is used for oil changes instead of the Kohler PRO® version, the filter must be changed every 200 hours.

△ Must be performed by an authorized Kohler Dealer.

## Check Engine Crankcase Oil

**Frequency:** Each use or after 8 hours of continuous operation

The engine is serviced with Kohler PRO® 10W-50 synthetic oil from the factory. Kohler PRO® oil is not required, but recommended. See “Specifications” for details.

**IMPORTANT:** The importance of checking and maintaining the proper crankcase oil level cannot be overemphasized. Check the oil level **BEFORE EACH USE**.

1. Park the mower on a **level surface with the engine stopped**. Also, make sure the engine is cool and oil has had time to drain into the sump [allow **at least five (5) minutes** after stopping the engine].

**IMPORTANT:** **NEVER** check or add oil with the engine running.

2. Before removing the dipstick, clean the area around the dipstick to keep any dirt or debris out of the engine.

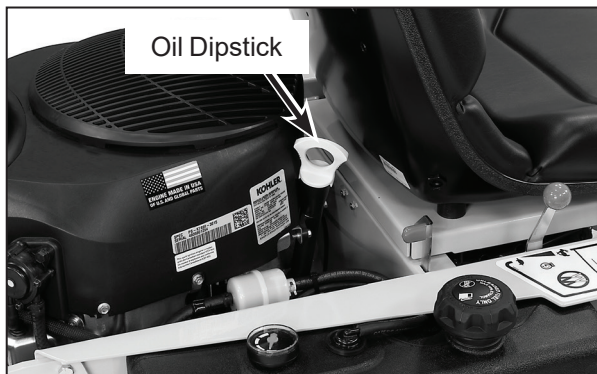

**Oil Dipstick Location**

3. Remove the dipstick, wipe off with a clean rag, then reinsert the dipstick into the tube and push it all the way down.
4. Remove the dipstick again and check the oil level on the dipstick. The oil level should be within the “Operating Range” on the dipstick (between the “L” mark and the “F” mark).

**IMPORTANT:** **DO NOT** operate engine without a sufficient oil supply in the crankcase. **DO NOT** operate with the oil level below the “L” mark or above the “F” mark on the dipstick.

5. If additional oil is needed, refer to “Specifications” on page 4 for proper crankcase lubricant. **Fill up to, but not above, the “F” mark on the dipstick.**

**IMPORTANT:** **DO NOT** overfill the crankcase (oil above “F” mark) as this **CAN** result in engine overheating, loss of power, and possible engine damage.

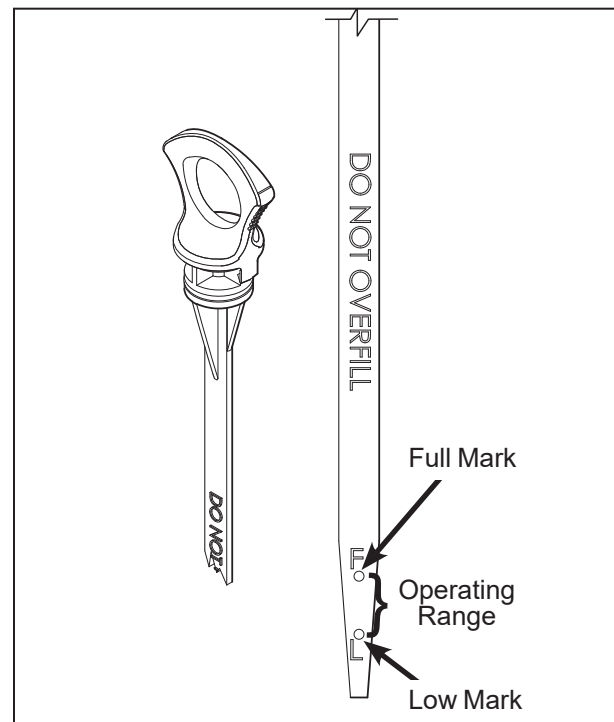

**Dipstick Operating Range**

## Check/Clean Engine Air Cooling System

**Frequency:** Each use or after 8 hours of continuous operation

To prevent engine overheating and possible engine damage, clean grass clippings, chaff, and dirt from the engine cooling air intake screen guard and the rotating screen below it each time you mow or after every 8 hours of operation. **In certain mowing conditions (dry grass, leaves, tree "cotton", etc.) it may be necessary to check and clean the screen several times each day to prevent engine overheating.**

1. With the engine stopped, clean all the debris off the air intake stationary screen guard and the rotating air intake screen below the guard. The best way to clean the screens is to use compressed air to blow the screens clean, but do not use a pressure washer. This can cause damage to the engine.

**NOTE:** For better access to the rotating screen and a more thorough cleaning, remove the screen guard. The guard is secured with a single screw along the front edge of the engine.

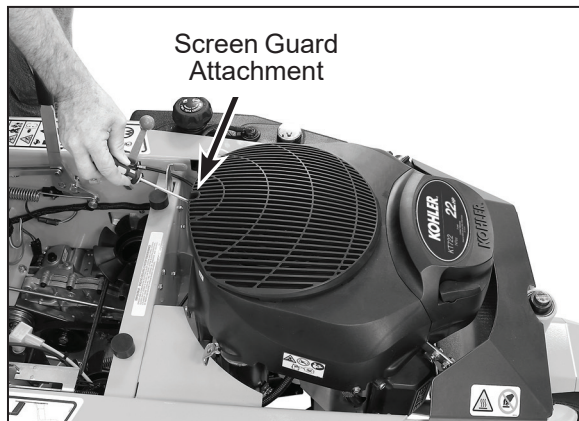

Remove the Stationary Screen Guard

2. Start the engine. With the engine running at full throttle, hold a hand above the engine air intake screen to feel for airflow. If there is little or no airflow, the cooling fan and cylinder head cooling fins are clogged. The engine shroud needs to be removed and the air cooling

system cleaned. See your authorized Walker Dealer for this service.



Checking Engine Air Flow

### CAUTION

Operating the engine with a blocked air intake screen, dirty or plugged cooling fins, and/or cooling shrouds removed will cause engine damage from overheating.

### CAUTION

DO NOT use a pressure washer to clean the cooling system on an air-cooled engine. Mud may form under the cooling shroud on the cylinder head and cooling fan and block cooling airflow.



## Clean Grass Buildup Under Deck

**Frequency:** Each Use

### DANGER

Before raising the mower deck for cleaning, stop the engine, and remove the ignition key.

1. Place the deck in the tilt-up position. For details on this procedure, see “Deck Tilt-Up Position” on page 29.

### DANGER

Do not operate the mower with deck in tilt-up position. Do not move the tractor with the deck in the tilt-up position.

2. Clean grass buildup underneath the deck using a pressure washer (and scraper if required).

**NOTE:** While some degree of material buildup in the mower deck housing can be tolerated, a point is finally reached **where cutting quality deteriorates and clogging begins to occur** because of too much buildup on the baffling and housing.

**NOTE:** While the deck is in the tilt-up position, it is recommended to visually inspect the blades. For more information, see “Inspect/Service Mower Blades” on this page.

3. Lower the deck to the normal operating position and re-engage the deck lock levers.

### CAUTION

Do not operate machine with deck tilt-up pivot joint unlocked.

## Inspect/Service Mower Blades

**Frequency:** Each use or after 10 hours of operation

Check mower blade(s) for straightness, sharpness, and condition of the cutting edge. Replace blades if worn, bent, cracked, or otherwise damaged.

Sharpen the blades after every 10 hours of operation (or more often when mowing abrasive type grass or operating on sandy soils).

**NOTE: Keep blades sharp.** Cutting with dull blades not only yields a poor mowing job but slows the cutting speed of the mower and causes extra wear on the engine and blade drive by pulling hard.

### DANGER

Before raising the mower deck for service, stop the engine, and remove the ignition key.

1. Place the deck in the tilt-up position. For details on this procedure, see “Deck Tilt-Up Position” on page 29.

### DANGER

Do not operate the mower with deck in tilt-up position. Do not move the tractor with the deck in the tilt-up position.

2. Check the blades for **straightness** by marking the blade tip position inside the deck housing, and then rotating the opposite end of the blade to the same position and comparing. If the difference in blade tip track is **more than 1/8 in. (3 mm)**, the blade is bent and **should be replaced**.

**WARNING**

DO NOT try to straighten a blade that is bent. NEVER weld a broken or cracked blade. ALWAYS replace with a new blade to assure safety.

3. Visually inspect the cutting edge. If the cutting edge is **dull or nicked**, it should be sharpened using the following procedure:

**NOTE:** If you are not comfortable performing the following steps, contact your authorized Walker Dealer for assistance.

To Sharpen the Blades:

- A. Remove blades for sharpening by grasping the end of the blade using a rag or a thick, padded glove, while loosening and removing the bolt and flat washer that mount the blade.
- B. Grind cutting edge at the same bevel as the original. Sharpen only the top of the cutting edge to maintain sharpness.

**NOTE:** Blades can be sharpened with an electric blade sharpener, conventional electric grinder, or a hand file.

**CAUTION**

ALWAYS wear eye protection and gloves when sharpening a blade.

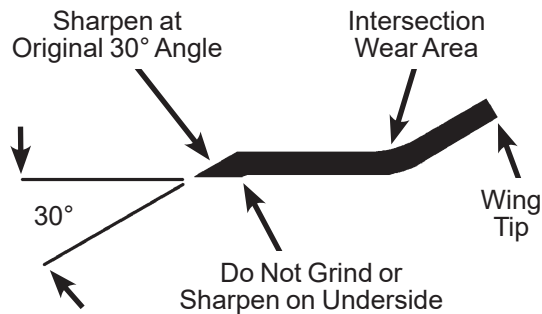

**Mower Blade Profile for Sharpening**

- C. Check blade balance by positioning the blade **horizontally** on a blade balancer or use a nail or shaft through the center hole. If either end of the blade rotates downward, grind (remove) metal on that end until the blade will balance. The blade is properly balanced when neither end drops. Balance of a blade is generally maintained by removing an equal amount of material from each end of the blade when sharpening.

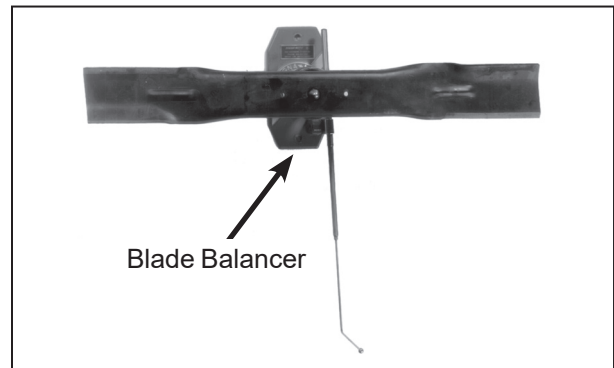

**Blade Balanced on Magnetic Wall-Mounted Balancer**

- D. Mount the blade with wing tips pointing up into the housing. Reinstall the blade, washer, and bolt. Tighten the bolt to **70 lb·ft (95 N·m)**.

## Check Security of Air Filtration Components

**Frequency:** Each Use

Inspect the engine air cleaner system to make sure it is securely in place and without damage. The levers on the cover should be rotated inward to maintain a locked position.

**NOTE:** Operating the engine with a loose or damaged air filter could cause premature wear to and failure of the engine.

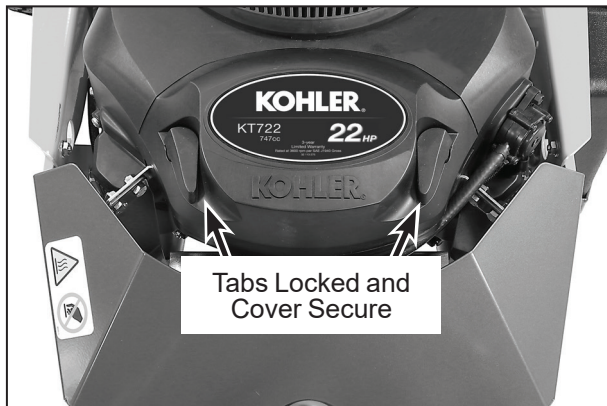

Air Filtration Installed

## Check Discharge Shield

**Frequency:** Each Use

Never operate the mower without the discharge shield in place. It prevents objects from being thrown when the blades are engaged. Inspect the discharge shield to make sure it is securely installed and not damaged. Lower it into the down position once it has been inspected.

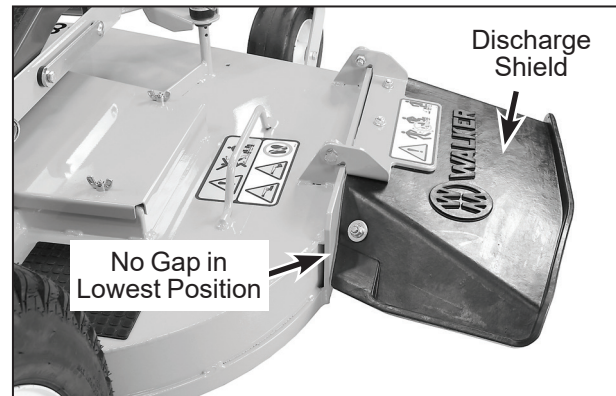

Discharge Shield Lowered

## Lubricate Grease Fittings and Oil Points

**Frequency:** Every 25 hours or more often in extremely dusty or dirty conditions

When lubricating the tractor or deck, use **SAE general purpose lithium or molybdenum base grease** for grease points and **light machine oil (SAE 10)** for oil points.

ID #	Location	Type	# of Places
1	Deck Caster Wheel Fork Pivot	Grease	2
2	Deck Caster Wheel Bearing	Grease	2
3	Idler Arm Pivot	Grease	1
4	Blade Spindle	Grease	2*
5	Steering Lever Pivot	Grease	2
6	Throttle Cable	Oil	2
7	Engine Dipstick and Oil Fill	Oil**	1
8	Belt Tensioner Arm	Grease	1

\* Three (3) spindles and grease points on DS54-R

\*\* Refer to "Change Engine Crankcase Oil and Filter" on page 44 for details on changing the engine oil and filter.

**NOTE:** The Blade Spindle grease points are accessed by lifting the deck, and the Steering Lever Pivot grease points are accessed by lifting the seat panel.

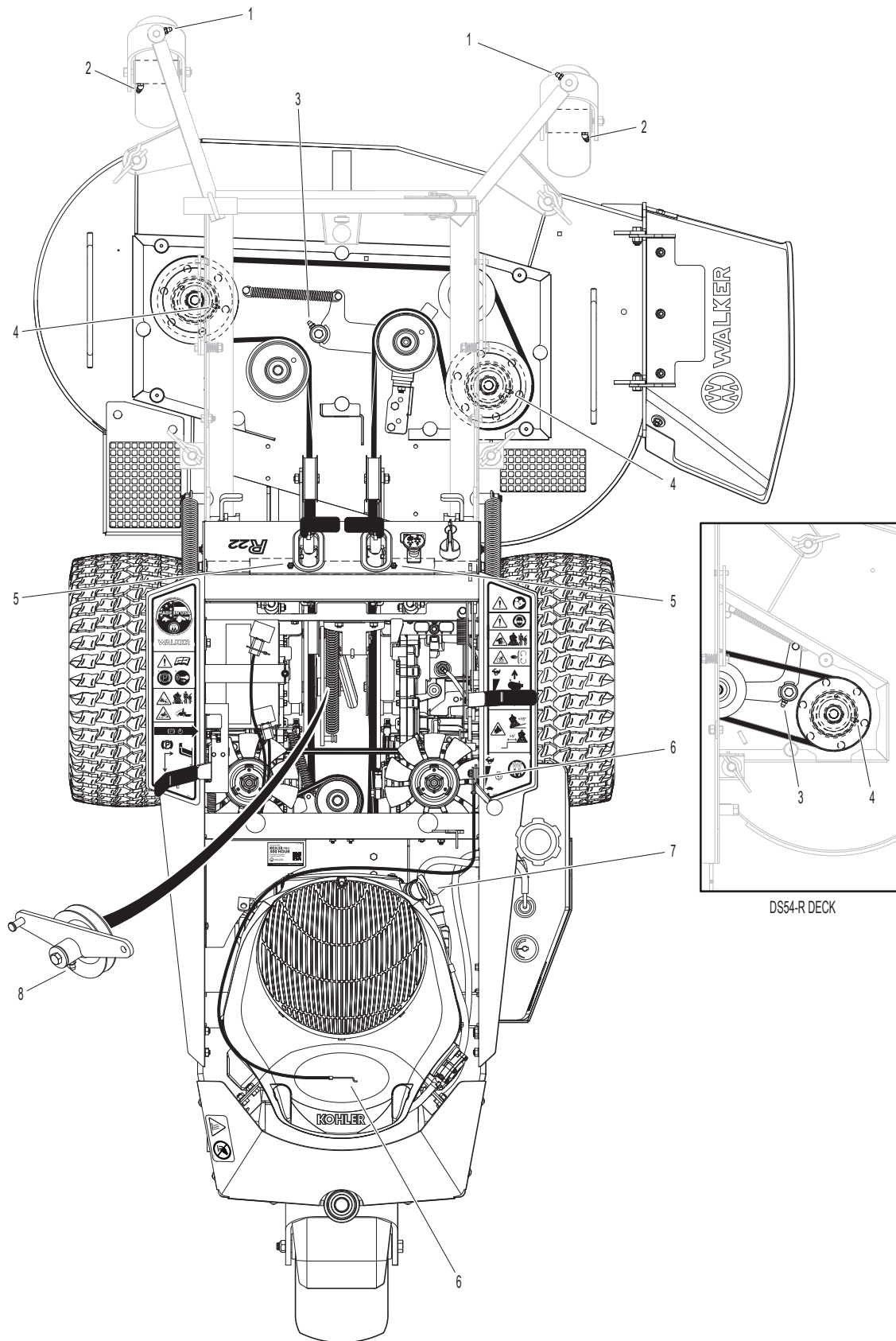

Lubrication Points

## Check Tire Pressure

**Frequency:** Every 25 hours

Inflate tires to the pressures shown below:

Drive Tires = 15 PSI (103 kPa)

Tailwheel = 20 PSI (137 kPa)

## Check Drive Belts (Ground Drive, Blade)

**Frequency:** Every 25 hours

There are two belts used for the R22: the blade drive belt and the ground drive belt. They need to regularly be inspected for wear.

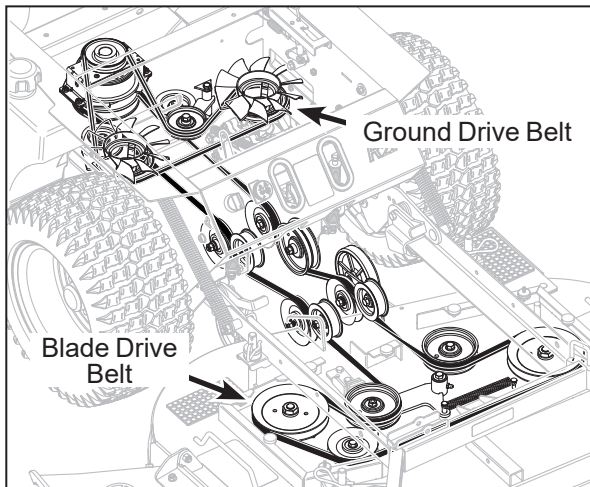

**R22 Belts**

1. With the engine turned off, raise the seat panel for access to the ground drive belt. Visually inspect the belt.
2. If the belt shows signs of cracking or deteriorating, the belt must be replaced. See "Belt Replacement" on page 51 for details.
3. Raise the footrest on the deck.
4. Remove the four (4) wing nuts on the deck belt cover and slide the cover out. Visually inspect the Blade Drive Belt.
5. If the belt shows signs of cracking or deteriorating, the belt must be replaced. See "Belt Replacement" on page 51 for details.

## Check Safety Switch System

**Frequency:** Every 25 hours

### **WARNING**

It is important to check and maintain the safety switch system for safe operation of the machine.

There are five (5) safety interlock switches on the tractor: seat switch, FSC Neutral-Park switch, PTO switch, parking brake switch, and deck hinge lock switch. These safety switches work together to ensure that the mower engine can only be started when **all** the following criteria is met:

- The **Forward Speed Control (FSC)** is **disengaged** in NEUTRAL-PARK.
- The **blade clutch (PTO)** is **disengaged**.
- The **parking brake** is **engaged**.
- The **deck hinge** is **locked**.

The operator does not need to be seated to start the engine. The operator does need to be seated before the Forward Speed Control (FSC) can be engaged, the blade clutch (PTO) can be engaged, or the parking brake can be disengaged.

The following combinations should be tested to ensure all the safety switches are functioning properly:

- With or without an operator in the seat and with the engine running (with the PTO disengaged for safety reasons), disengage the deck hinge lock located on the RH hinge and the engine should immediately stop.

- Without an operator in the seat and the with engine running, any of the following changes should cause the engine to immediately stop:
  - Disengaging the parking brake
  - Moving FSC out of NEUTRAL-PARK
  - Engaging the blade clutch (PTO)
  - Disengaging the deck hinge lock
- With or without an operator in the seat, when the FSC is not in NEUTRAL-PARK but all remaining start conditions are met, the engine should not start.
- With or without an operator in the seat, if the parking brake is disengaged but all remaining start conditions are met, the engine should not start.
- With or without an operator in the seat, if the blade clutch (PTO) is engaged but all remaining start conditions are met, the engine should not start.

If any of these safety switch checks fail, contact your Walker Dealer for service.

In addition, if you experience the engine stopping during what should be **normal operation**, it could be caused by a failure of a safety switch. For example:

- An operator is in the seat, the engine is running, the parking brake is disengaged, and the engine stalls when the FSC is moved out of NEUTRAL-PARK.
- An operator is in the seat, the engine is running, the parking brake is disengaged, and the engine stalls when the blade clutch (PTO) is engaged.

Contact your Walker Dealer for troubleshooting and/or service if you experience failure-to-operate conditions such as these.

## Clean/Replace Engine Precleaner Air Filter

**Frequency:** Every 25 hours or more often in extremely dusty or dirty conditions

The precleaner can be washed or replaced depending on its condition.

1. With the engine stopped, clean off the area around the air filter cover to prevent debris from falling in. Rotate the levers on the engine air cleaner cover outward to unlock the cover. Remove the cover.

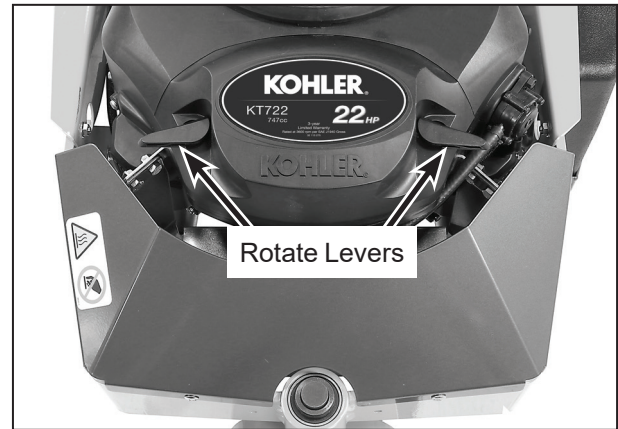

**Unlock Air Filter Cover**



**Engine Precleaner Filter**

2. Slide the precleaner foam filter off the paper filter element.
3. Inspect the precleaner to determine if it can be washed or if it needs to be replaced. If there is damage to the precleaner, replace it using the recommended Kohler replacement pre-cleaner. (Kohler P/N 16 083 05-S)

4. Wash precleaner in warm water with detergent. Rinse and allow to air dry. (Do not wring dry.)
5. Lightly oil precleaner with new engine oil; squeeze foam to distribute oil and remove excess oil.
6. Reinstall the precleaner over the paper filter element.
7. Position the air cleaner cover with the levers facing outward over the air cleaner. Rotate the levers inward to lock the cover into place.

## Replace Engine Air Filter

**Frequency:** Every 75 hours or more often in extremely dusty or dirty conditions

**NOTE:** This filter cannot be blown off with compressed air. It must be replaced if dirty or damaged.

1. With the engine stopped, rotate the levers on the engine air cleaner cover outward to unlock the cover. Remove the cover.
2. Slide the precleaner off of the paper filter element and service the precleaner using the steps provided in the section "Clean/Replace Engine Precleaner Air Filter" on page 42.
3. Remove the paper filter element from the base and discard it.
4. Install the serviced precleaner over the new paper filter element, and install them together on the base. Use **ONLY** the recommended Kohler replacement filter. (Kohler P/N 16 083 04-S)
5. Position the air cleaner cover with the levers facing outward over the air cleaner. Rotate the levers inward to lock the cover into place.

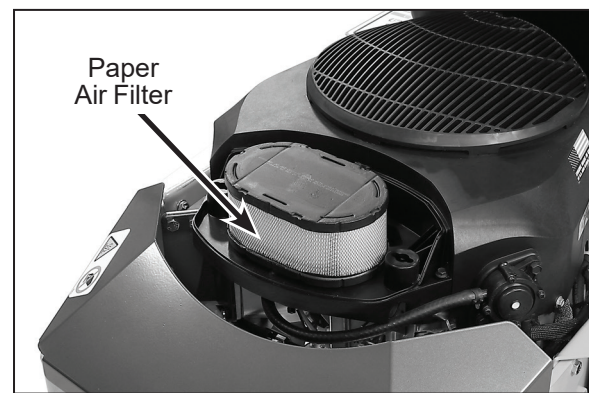

Engine Air Filter

## Change Engine Crankcase Oil and Filter

**Frequency:** Every 300 hours if the recommended Kohler PRO® oil and filter are used or every 100 hours for conventional oil and 200 hours for conventional filter

The engine is serviced with Kohler PRO® 10W-50 synthetic oil and a Kohler PRO® filter from the factory. Both are rated for 300 hour oil change intervals. Kohler PRO® oil and filter are not required, but recommended. If conventional oil and filters are used in the tractor, the oil must be changed **after every 100 hours** of operation, and the filter must be changed **after every 200 hours**. See the “Specifications” section for details on which oil and filters are recommended. A break-in oil change is not required.

1. Run the engine for at least 10 minutes in a well-ventilated area. The engine oil should be warm before draining.

### **WARNING**

NEVER run the engine in an enclosed or poorly ventilated area. Engine exhaust contains carbon monoxide, an odorless and deadly gas.

2. Park the mower on a level surface with the engine stopped and the key removed from the ignition.
3. Before removing the dipstick, clean the area around the dipstick to keep any dirt or debris out of the engine.
4. Remove the dipstick and oil drain plug, and drain the oil into a suitable container. The oil drain is located behind the left drive tire. Be sure to allow ample time for complete drainage.



**Oil Dipstick and Oil Fill Location**

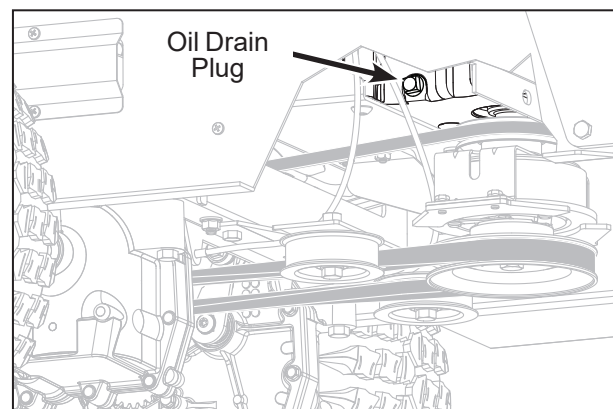

**Oil Drain Location (on LH Side of Engine)**

### **WARNING**

Use caution when draining the oil because it may be very hot. Wear appropriate protective gear to avoid being burned or exposed to the engine oil.

5. Before removing the oil filter, clean the area around the filter to keep dirt and debris out of the engine.





**Oil Filter Location  
(Beneath the Fuel Filter)**

6. Remove the old oil filter and wipe off the filter mounting surface on the engine.
7. Apply a thin coating of clean oil to the rubber gasket on the replacement oil filter.

**IMPORTANT:** Use **ONLY Kohler** oil filters. See the “Specifications” section for a list of recommended filters. Aftermarket oil filters may not seal properly and/or may not have the correct pressure relief valve for proper lubrication.

8. Install the new oil filter on the engine. Turn the filter clockwise until the rubber gasket contacts the sealing surface, then tighten an additional **3/4 to 1 turn**.
9. Reinstall the drain plug and torque to 10 lb·ft (13.6 N·m). Do not overtighten.
10. Fill the crankcase with new, clean oil. Use only crankcase lubricants recommended by the engine manufacturer. Refer to “Specifications” on page 4 in this manual or the Kohler Owner’s Manual. Use the recommended oil viscosity for the expected ambient temperature. Oil with the correct viscosity will aid starting in cold weather and assure proper lubrication in hot weather. **Fill up to, but not above, the “F” mark** on the dipstick. Crankcase capacity is 2 quarts (1.9 liters) plus 1/2 pint (0.24 liters) for the new oil filter.

**IMPORTANT:** Check the dipstick reading before adding the last 1/2 pint of oil and **fill only to the “F” mark**. **DO NOT** overfill the crankcase (oil above “F” mark) as this **CAN** result in engine overheating, loss of power, and possible engine damage.

11. Start the engine and check for oil leaks around the oil filter and the drain plug. Stop the engine, recheck the oil level, and add oil if necessary. (When the engine is first operated with a new oil filter, the oil level will drop slightly as the filter is filled with oil.)
12. Dispose of the used oil and filter in accordance with local ordinances.

## Clean Engine Cooling System

**Frequency:** Every 100 hours

It is essential for performance and longevity of the air-cooled engine to keep the cooling fan and the cylinder head cooling fins clean and free of obstruction. Even with regular cleaning as detailed in “Check/Clean Engine Air Cooling System” on page 36, the fan and the fins can become dirty or clogged. Kohler recommends removing the engine cooling shroud and cleaning the cooling system every 100 hours. This procedure requires removing the engine from the chassis. See your authorized Walker Dealer for this service.

### **CAUTION**

DO NOT use a pressure washer to clean the cooling system on an air-cooled engine. Mud may form under the cooling shroud on the cylinder head and cooling fan and block cooling airflow resulting in engine overheating.

## Replace Fuel Filter

**Frequency:** Every 100 hours

A 10 micron in-line fuel filter is installed between the fuel tank and the fuel pump. Replacement of this filter is recommended every 100 hours of operation or when contamination is suspected or found in the fuel.

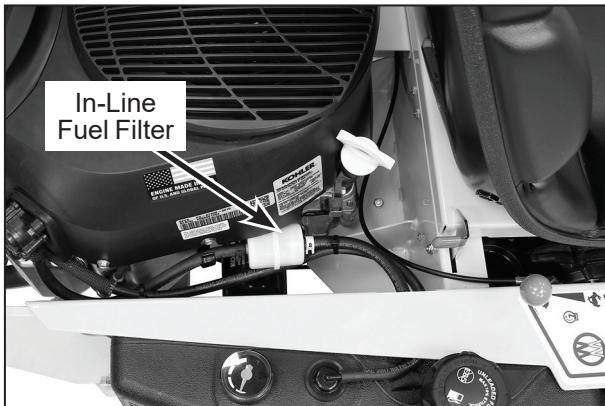

**Fuel Filter Location**

**IMPORTANT:** Replace the fuel filter only in a clean area where the fuel line and connections will not be contaminated by dust and dirt.

1. Expand and slide clamps on either side of the filter away from filter and pull fuel lines off filter.
2. Replace the filter using Walker Service Parts (Walker P/N 5020-3), making sure that the arrow on the filter is aligned with the fuel flow through the filter.
3. Verify that the fuel lines and clamps are securely attached, and that no fuel leaks are present.

## Clean Transaxle Housing and Fans

**Frequency:** Every 100 hours

Keeping the housing on the transaxles clean and free of obstruction is **essential to avoid overheating** the transaxle fluid and shortening transaxle life.

1. With the engine turned off and key removed from the ignition, raise the seat panel for access to the transaxles.
2. Use compressed air and/or a pressure washer to clean the transaxle housing. Pay close attention to any oily dirt buildup. This may be the result of an oil leak. If an oil leak is noted, contact your local Walker Dealer.

**IMPORTANT:** In case an oil leak develops, the cooling fan blowing dusty air and oil on the transaxle will **quickly** cover the housing and pack the cooling fins with **oily dirt**. If this condition occurs, contact your dealer immediately to avoid overheating and damaging the transaxle.

3. Inspect the cooling fans, and replace the fan(s) if blades are missing or damaged.

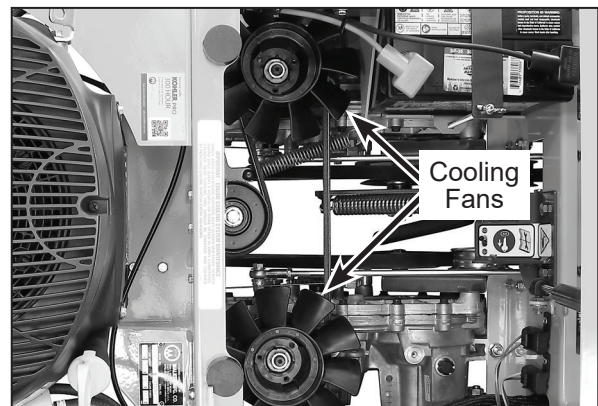

**Transaxle Housing and Cooling Fans**

**NOTE:** The transaxle is filled with oil at the factory and sealed. It does not require oil maintenance. In the event of oil loss or performance degradation, contact an authorized Walker Dealer.

## Check Drive Tire Mounting Nuts

**Frequency:** Every 100 hours

There are four (4) mounting nuts on each drive tire. Check the mounting nuts to ensure they remain secure. They should each be torqued to 75 to 85 lb·ft (102 to 115 N·m).

## Check Blade Brake Function

**Frequency:** Every 100 hours



### **WARNING**

It is important to check and maintain blade brake action for safe operation of the machine.

This mower is designed with a blade brake that should stop all rotation within five (5) seconds of disengaging the clutch. This is a safety feature that should be checked to confirm it is working properly.

1. With the operator seated and the engine running, engage the blade clutch (PTO).
2. Operate the engine at full throttle and then disengage the blade clutch. Listening for the blades to stop moving, measure how long it takes.
  - If the brake is working properly, all rotation will stop five (5) seconds after disengagement of the clutch.
  - If the brake system malfunctions [the blades do not stop within five (5) seconds], the brake needs to be repaired or replaced before operating the mower. Contact your local Walker Dealer.

## Replace Spark Plugs and Set Gap

**Frequency:** Every 500 hours

**NOTE:** If you are not experienced with engine maintenance or comfortable performing the steps outlined below, contact your Walker Dealer for assistance.

1. With the engine turned off and the ignition key removed, use compressed air to clean the areas around the base of the spark plug and the spark plug covers to keep dirt and debris out of the engine. There are access holes in the chassis for the spark plugs. See "Rear View and Left Side View" on page 8 for location.
2. Remove the spark plugs. Replace the spark plugs with Champion® type RC12YC (or equivalent).
3. Check the gap for each plug using a wire-type feeler gauge, and set the gap at 0.030 in. (0.76 mm).
4. Reinstall each plug and torque to 20 lb·ft (27 N·m).

## Check/Adjust Engine Valve Lash

**Frequency:** Every 500 hours

This maintenance must be performed by an authorized Kohler Dealer. Contact your Walker Dealer for assistance (if they are a Kohler Dealer) or to help you locate a Kohler Dealer in your area.

## Check FSC Friction Lock

**Frequency:** Yearly

The Forward Speed Control (FSC) is designed to have enough friction to **hold the selected forward travel speed** when the steering levers are moved and yet not so much as to make **moving the FSC control difficult**.

1. With the engine off, place the FSC in the full FORWARD position and pull both steering levers back. The FSC lever should not move. If the FSC lever moves back when the steering levers are pulled back, the friction needs to be increased.



**FSC Friction Adjustment Test**

2. With the steering levers pulled back, move the FSC lever back from the FORWARD position. With a proper amount of friction adjusted, the FSC lever should move back with a slight amount of resistance (friction). If the FSC lever movement is “stiff”, the friction needs to be decreased.

If the FSC friction lock needs to be adjusted, refer to “Forward Speed Control Friction Adjustment” on page 58 or contact your Walker Dealer.

## Check Transmission Control Settings

**Frequency:** Yearly (or when an out-of-adjustment condition is observed)

### Check Neutral-Park Position

With the mower parked on level ground, start and run the engine, first at idle and then normal operating speeds. With the FSC in the **NEUTRAL-PARK** position, there should be no movement of either drive tire. If the tire(s) are “creeping” forward or reverse, refer to “Neutral Function Adjustment” on page 59.

### Check Straight Ground Tracking

Check for straight ground track by driving on a smooth, level surface with hands off the steering levers. Set the FSC at different speeds and observe if the mower moves in a straight line (use a cement joint or other line on the ground for reference). If the machine is drifting to the right or left, refer to “Straight Tracking Adjustment” and “Maximum Forward Speed Adjustment” on page 60.

## Check Fuel Lines and Clamps

**Frequency:** Yearly

Inspect the fuel supply line from the tank to engine for deterioration or damage. Also, inspect the fuel line clamps for tightness. Good preventive maintenance calls for complete replacement of fuel lines and clamps every two (2) years. If your lines need to be replaced, contact your local Walker Dealer.

## Clean Battery Terminals

**Frequency:** Yearly

The battery comes sealed and is maintenance free, so the electrolyte level will not need to be checked or filled. Annually the battery terminals need to be inspected and cleaned.

1. With the engine turned off and the key removed from the ignition, raise the seat panel for access to the battery.
2. Inspect the battery terminals. If the terminals are corroded, remove the battery from the mower by disconnecting the negative (black) terminal first.
3. Using a wire brush, remove the corrosion with a solution of **one part baking soda and four parts water**. Rinse with clean water. Coat the terminals with petroleum jelly or terminal protector spray to retard further corrosion.
4. Reinstall the battery and make sure it is securely installed in place. Reconnect the terminal starting with the positive (red) terminal first.

If the mower will not be used for an extended time, see the section "Long-Term Storage Preparation" for tips to protect the battery.

**IMPORTANT:** Make sure battery is securely mounted in the frame. A loose battery may cause damage to the case resulting in acid leakage and severe damage to the machine. A hazard may be created by damage to critical working parts and safety systems.

## Charge Battery

**Frequency:** Yearly (or as required)

 **DANGER**

### BATTERIES PRODUCE EXPLOSIVE GASES

- Charge the battery in a well-ventilated area, so that gases produced while charging can dissipate.
- Keep sparks, flames, and smoking materials away from the battery at all times.
- Make sure the battery charger is unplugged before connecting or disconnecting cables to the battery.

Charge the battery at 15 amps for 10 minutes. **DO NOT** exceed 20 amps (maximum recommended charging rate). Total charging time should not exceed one (1) hour.

## Long-Term Storage Preparation

**Frequency:** For storage of longer than two (2) months

At the end of the mowing season, the mower should be serviced and prepped for storage to protect the equipment from damage.

### Mower Preparation for Storage

1. Thoroughly clean the mower and deck by removing all grass and dirt. Use a blower or a low pressure wash to perform this step.

**IMPORTANT** If using water to clean your machine, avoid using excessive water. It can damage the electronics or the engine. **Only use a pressure washer** to clean the underside of the deck.

2. Perform any yearly maintenance tasks that have not already been completed.
3. Check for any worn or damaged parts and order replacements from your dealer.
4. Lubricate the grease fittings and oil points using the details provided in the section “Lubricate Grease Fittings and Oil Points” on page 39.
5. Disconnect the battery starting with the negative (black) battery terminal and remove it from the mower. Store the battery in a cool, dry location where it won't be exposed to freezing temperatures. If your mower is stored in a climate controlled environment, you can leave the battery installed but disconnected.

**IMPORTANT:** Always keep the battery fully charged to prevent damage especially if it may be exposed to freezing temperatures. For instructions, see “Charge Battery” on page 49.

6. Complete the following “Engine Preparation for Storage” on this page.
7. Store the mower in a clean, dry environment.

### Engine Preparation for Storage

If the mower is to be stored for **more than two (2) months**, complete the following procedure to prepare the engine.



Refer to the section “Safety Before Operating” on page 10 that covers the safe handling of fuel before completing this procedure.

1. Add Kohler PRO® Series fuel treatment or equivalent to the fuel tank. Run the engine for three (3) minutes to get stabilized fuel into the fuel system.
2. Fill the fuel tank with fresh fuel.
3. Change the oil and replace the filter following the steps provided in the section “Change Engine Crankcase Oil and Filter” on page 44.
4. Remove spark plugs and pour 1 oz of engine oil into the cylinders. Replace spark plugs and crank engine slowly to distribute the oil.

### Restarting the Mower After Storage

After long-term storage, complete this procedure to make sure your mower is ready to perform.

1. Check the tire pressure and add air if necessary. See page 41 for details.
2. Check the engine oil level and add fresh oil if necessary. See the section “Check Engine Crankcase Oil” on page 35.
3. Install a fully charged battery and attach the battery cables.
4. If not done prior to storage, fill the fuel tank with fresh fuel. Run the machine at half speed for at least five minutes. After this time, check for oil leaks, losing fittings, and such.
5. Check the operation of the steering levers.
6. Tighten any bolts that have loosened and make sure all cotter and clevis pins are in place.

# Service and Adjustments

## In This Section...

Belt Replacement.....	51
Deck Leveling.....	57
Steering Handle Adjustment.....	58
Forward Speed Control Friction Adjustment.....	58
Neutral Function Adjustment.....	59
Straight Tracking Adjustment.....	60
Maximum Forward Speed Adjustment.....	60

The information covered in this section can be performed by qualified owner/operators or by a Authorized Walker Dealer.

### **DANGER**

To prevent accidental starting of the engine when servicing the machine, remove the key from the ignition switch and disconnect the spark plug wires.

## Belt Replacement

There are two (2) belts on the R22: the blade drive belt (PTO) and the ground drive belt. If either belt shows wear or damage during a regular inspection, the belt should be replaced.

**NOTE:** Only use Walker replacement belts on this machine.

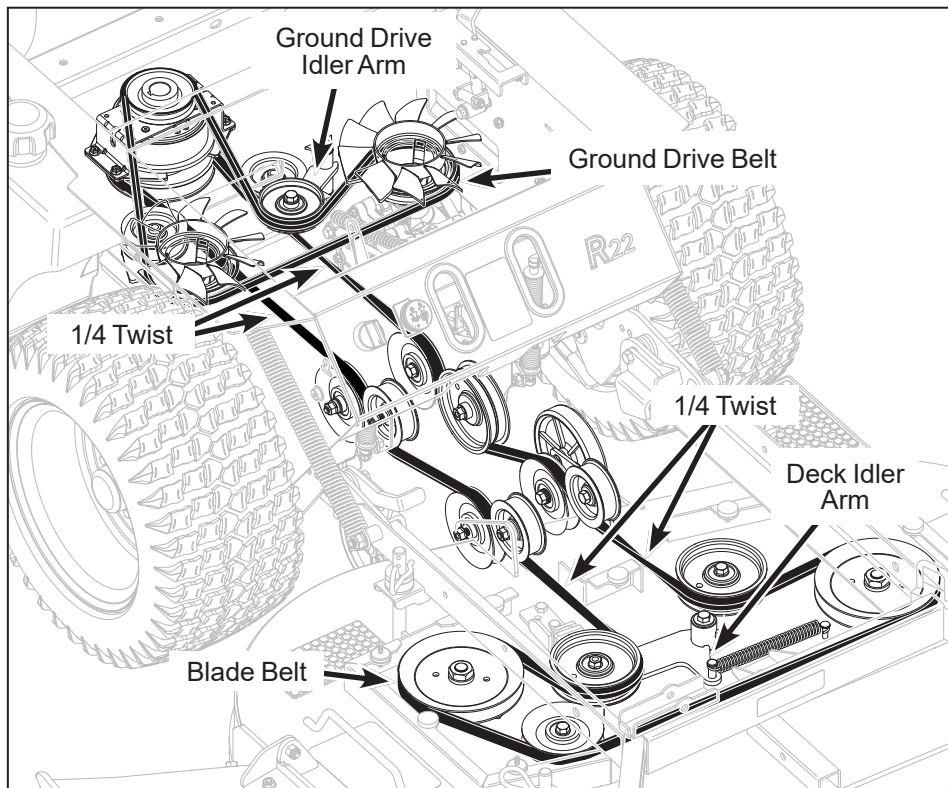

**R22 Belts**

### Replacing the Blade Drive Belt (PTO)

1. With the engine off and the key removed from the ignition, lift the seat panel. Unlock and lift the belt tensioner lever to disengage.

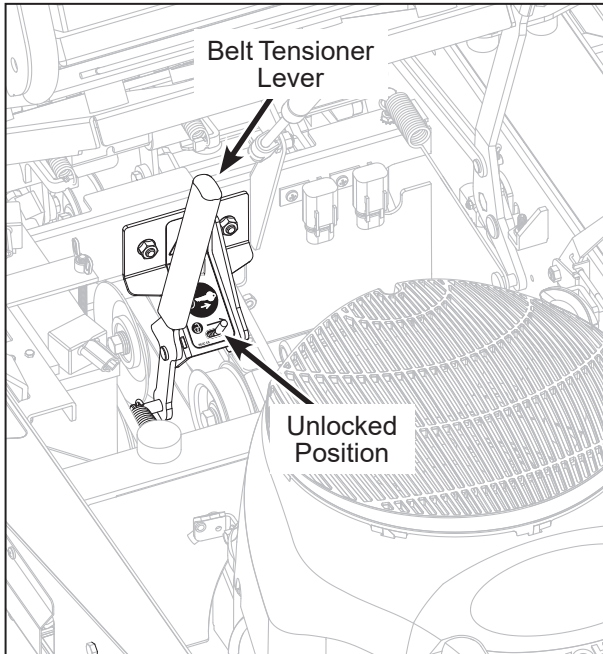

**Unlock and Disengage Belt Tensioner Lever**

2. Raise the footrest. Remove the four (4) wing nuts on the deck belt cover and slide the cover out.
3. **For a 42", 48" deck:** Push back on the tensioned idler, and remove the belt from the fixed LH idler.

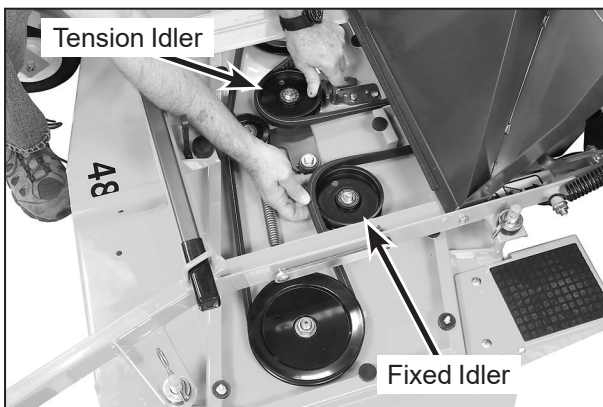

**42", 48" Deck: Removing Belt from LH Idler Pulley**

**For a 54" deck:** Pull back on the RH V-groove idler to rotate the deck idler arm and reduce tension. Once the belt is broken-in, you should be able to rotate this by hand, but a wrench is helpful for newer belts. Remove the extension spring, and remove the belt from the RH spindle pulley.

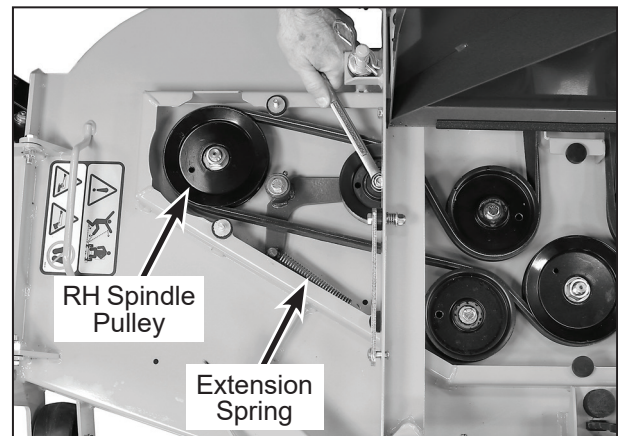

**54" Deck: Removing Belt from RH Spindle Pulley**

4. Remove the belt from around the remaining pulleys.
5. Remove the belt from the idler pulleys and clutch pulley below the engine, and discard it.
6. Slide a new belt [Walker P/N 1731-1 (42"), 1731 (48"), or 1731-2 (54")] under the tractor, and route it through the middle sets of idler pulleys. Unlock the carrier frame pivot joint on each side of the deck to lower the deck and give clearance to lift the drive belt cover. Lifting this cover provides access to the idler pulleys on the deck side.



**Lift Drive Belt Cover to Route the Belt**



**NOTE:** The Belt Routing decal located under the seat panel shows correct belt placement.

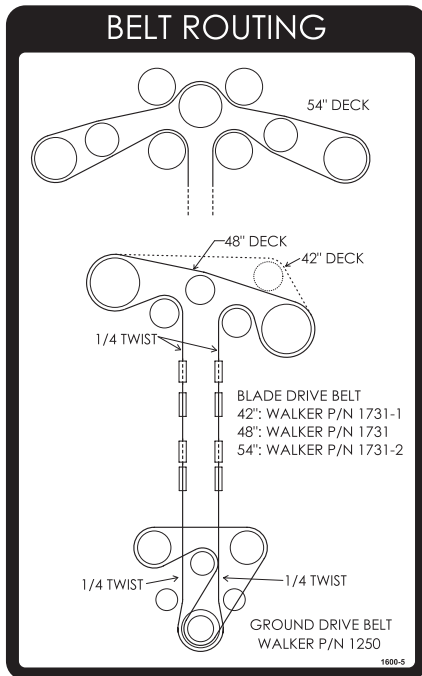

**Belt Routing Decal**

7. On the engine side, position the belt between the rear idler pulleys and around the clutch pulley. Be sure to add the 1/4 twist on each side forward of the rear idler pulleys. See the Belt Routing Decal for details.
8. On the deck side, position the belt around the pulleys. Use the Belt Routing decal as a guide. Be sure to have the correct 1/4 twist on each side as it enters the deck area.  
**For a 42", 48" deck:** Ignore the LH spindle during initial belt placement. Once the belt is placed, push back on the tensioned idler and reinstall the belt around the LH spindle.  
**For a 54" deck:** Pull back on the RH V-groove idler to rotate the deck idler arm and reinstall the extension spring.
9. Re-engage the belt tensioner lever in the tractor by pushing down on it. The lock will automatically engage.

**NOTE:** The pulley beside the tensioner extension spring may need to be pushed down to increase clearance for the tensioner arm before the lever can be engaged.

10. Check and adjust the effective belt length. With the drive belt in place, check the position of the front idler on the tensioning arm. The top of the idler should be even with to 1/2" below the edge of the chassis. If the idler is too high, adjust the positions of the deck idlers to effectively lengthen the belt. If the idler is too low, adjust the positions of the deck idlers to effectively shorten the belt.

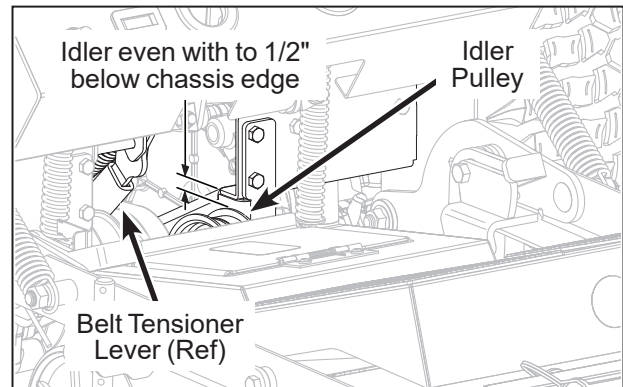

**Check Position of Front Idler on Tensioning Arm**

**For a 42", 48" deck:** To adjust for variations in belt length, the idler stop has two (2) mounting positions; it can be mounted forward to effectively shorten the drive belt or back to lengthen the belt. It comes from the factory mounted in the back position. The LH fixed idler has three (3) mount holes to effectively shorten or lengthen the belt and it comes from the factory mounted in the middle hole. Use any combination of mounting the idler stop and LH idler pulley to adjust for the correct **Position of Front Idler on Tensioning Arm** (as shown in illustration).

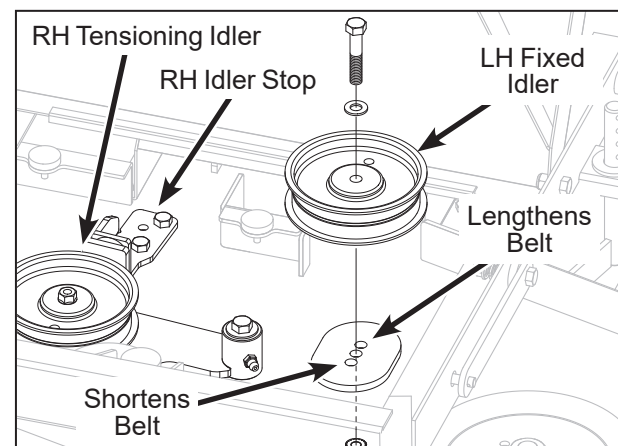

**Adjust Effective Belt Length (42", 48")**

**For a 54" deck:** The RH and LH fixed idlers can be moved forward (one or both) to effectively shorten the belt. They come mounted in the rear holes from the factory.

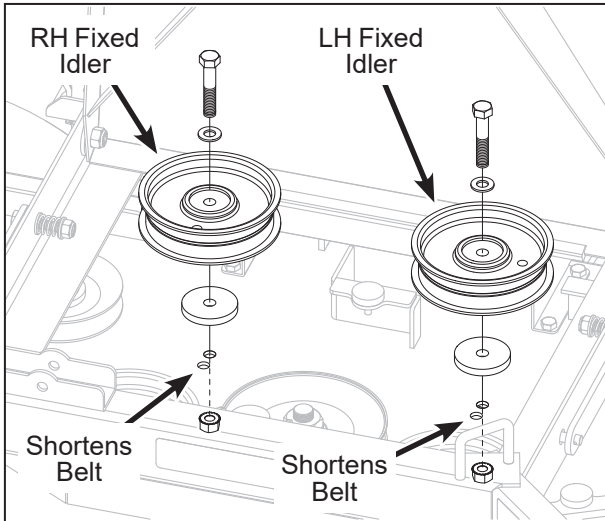

1. With the engine off and the key removed from the ignition, lift the seat panel. Unlock and lift the belt tensioner lever to disengage.

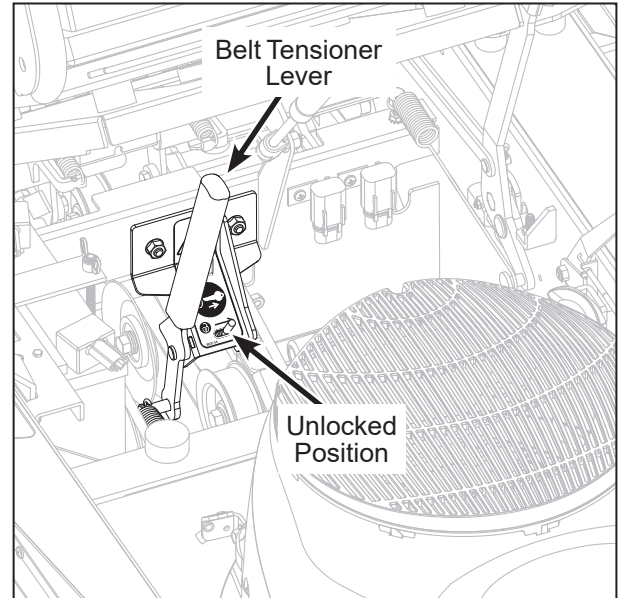

**Unlock and Disengage Belt Tensioner Lever**

2. Raise the footrest. Remove the four (4) wing nuts on the deck belt cover and slide the cover out.
3. **For a 42", 48" deck:** Push back on the tensioned idler, and remove the belt from the fixed LH idler.

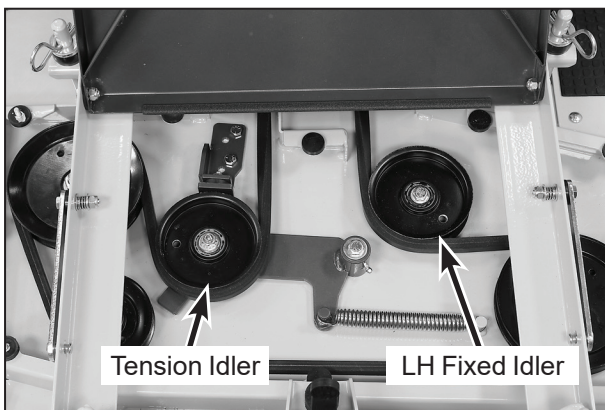

**Idler Pulleys (42" Shown)**

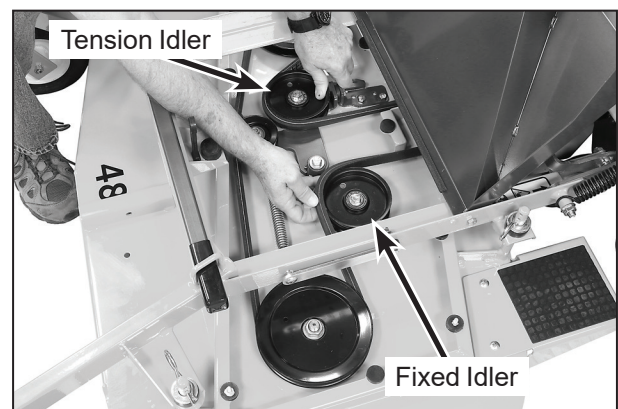

**42", 48" Deck: Removing Belt from LH Idler Pulley**

11. Lower the seat panel, raise and lock the carrier frame, and reinstall the deck belt cover. Tighten the four (4) wing nuts to secure the cover.

### Replacing the Ground Drive Belt

**NOTE:** The first part of this procedure involves loosening the blade drive belt and disconnecting the clutch wire to allow for the ground drive belt to be removed.

**For a 54" deck:** Pull back on the RH V-groove idler to rotate the deck idler arm and reduce tension. Once the belt is broken-in, you should be able to rotate this by hand, but a wrench is helpful for newer belts. Remove the extension spring, and remove the belt from the RH spindle pulley.

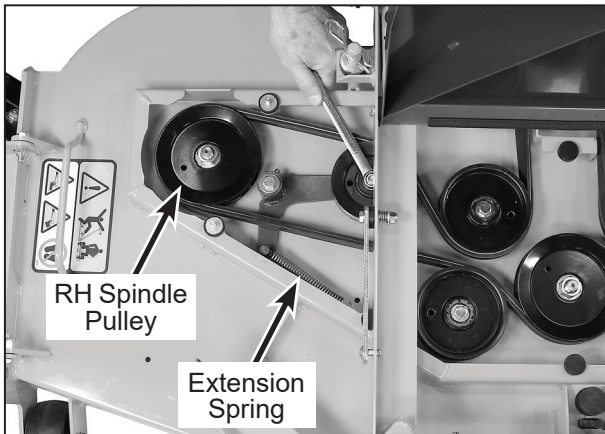

**54" Deck: Removing Belt from RH Spindle Pulley**

4. Remove the loosened blade drive belt from the clutch pulley directly below the engine.
5. Remove the solenoid guard by removing three (3) screws and nuts as identified in the **Remove Solenoid Guard for Clutch Wire Access** photo.

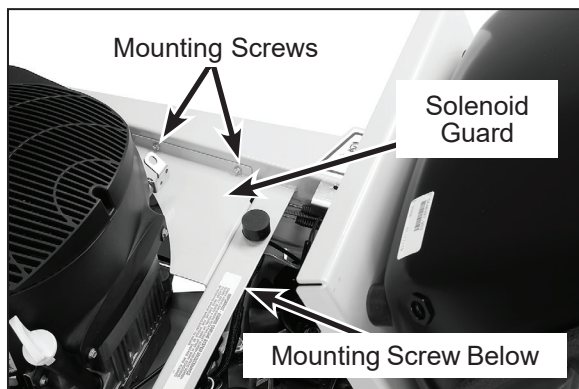

**Remove Solenoid Guard for Clutch Wire Access**

6. Disconnect the clutch wire as shown in the **Disconnect Clutch Wire** photo. Remove the mounting tie below the engine to free the wire for belt removal.

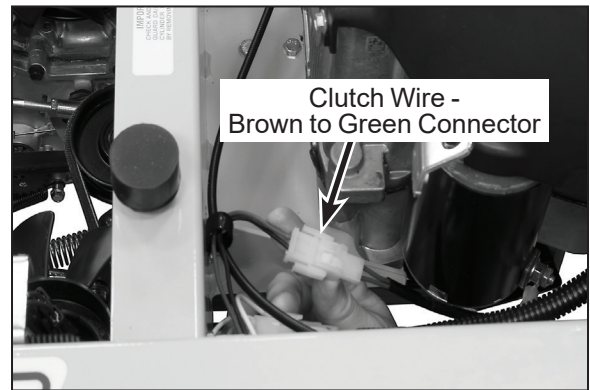

**Disconnect Clutch Wire**

7. Using a 9/16 in. (14 mm) wrench from the bottom of the ground drive idler arm pulley, push back to create slack in the belt. Lift the belt up off of the idler pulley.

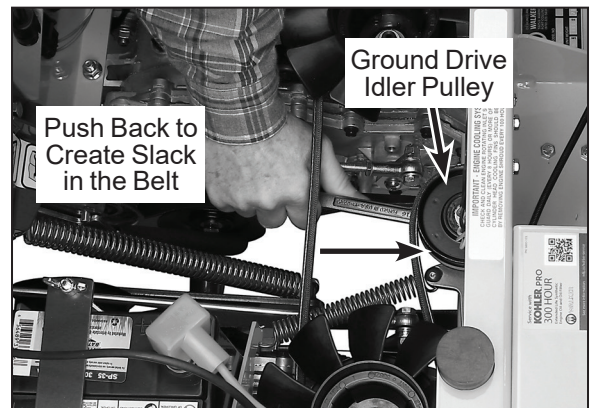

**Rotate Ground Drive Idler Arm to Loosen Belt**

8. Place belt between two blades of the transaxle fan and rotate fan to remove the belt as shown in the **Ground Drive Belt Between Transaxle Fan Blades** photo. Repeat on the other side.
9. Remove belt from the engine clutch pulley and slide the belt out.

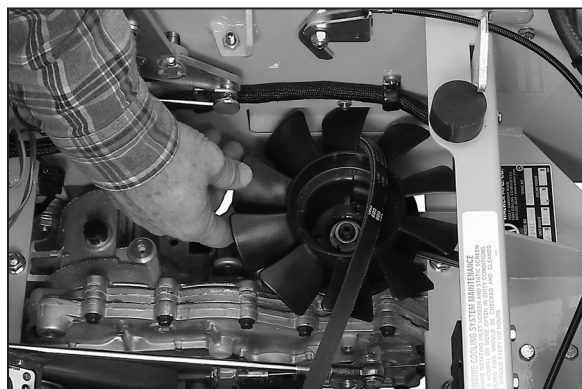

**Ground Drive Belt Between  
Transaxle Fan Blades**

10. Slide in the replacement ground drive belt (Walker P/N 1250), and position the belt on clutch pulley.
 

**NOTE:** The Belt Routing decal located under the seat panel shows correct belt placement.
11. Position the belt around the transaxle fans using the same technique that was used to remove it.
12. Using the 9/16 in. (14 mm) wrench, rotate the ground drive idler arm to install the new belt around the idler pulley. Release the idler pulley to tension the belt.
13. Reconnect the clutch wire, replace the mounting tie for the clutch wire, and reinstall the solenoid guard.
14. On the engine side, position the belt between the rear idler pulleys and around the clutch pulley. Be sure to add the 1/4 twist on each side forward of the rear idler pulleys. See the Belt Routing Decal for details.
15. Re-tension the blade drive belt in the deck.
 

**For a 42", 48" deck:** Push back on the tensioned idler, and reinstall the belt around the LH spindle.

**For a 54" deck:** Pull back on the RH V-groove idler to rotate the deck idler arm and reinstall the extension spring.
16. Reinstall the belt cover on the deck.
17. Lower the footrest.
18. Re-engage the belt tensioner lever in the tractor by pushing down on it. The lock will automatically engage. Lower the seat panel.
 

**NOTE:** The pulley beside the tensioner extension spring may need to be pushed down to increase clearance for the tensioner arm before the lever can be engaged.

## Deck Leveling

The mower deck and support frame are jig welded; within normal tolerances, very little, if any, shimming should be required to level the deck. Tire pressure will influence the levelness of the deck. Check the tire pressure of all pneumatic tires as a possible cause of the deck not being level.

1. Position mower on a smooth, level surface. Turn off the engine and remove the ignition key.
2. Set the cutting height to the highest position at 4 in. (102 mm) - for easy access under the deck to measure blade height. Refer to "Adjusting the Cutting Height" on page 29.

**NOTE:** A block of wood cut 4 in. (102 mm) high is a convenient gauge to measure blade height above ground during the leveling process.

3. Check the side-to-side level. **Rotate each blade sideways** and measure the distance from blade tip to ground on each side. If measurements vary more than 1/8 in. (3 mm), add a washer shim under the deck support pins on the low side to level the deck.
4. Check the front-to-rear level. **Rotate the blades to point forward.** Measure the distance from blade tip to ground on the front and rear. The rear of the blade should be 1/8 to 1/4 in. (3 to 6 mm) higher than the front of the blade; shim the rear (or front) deck support pins equally to achieve at least 1/8 in. (3 mm) difference.

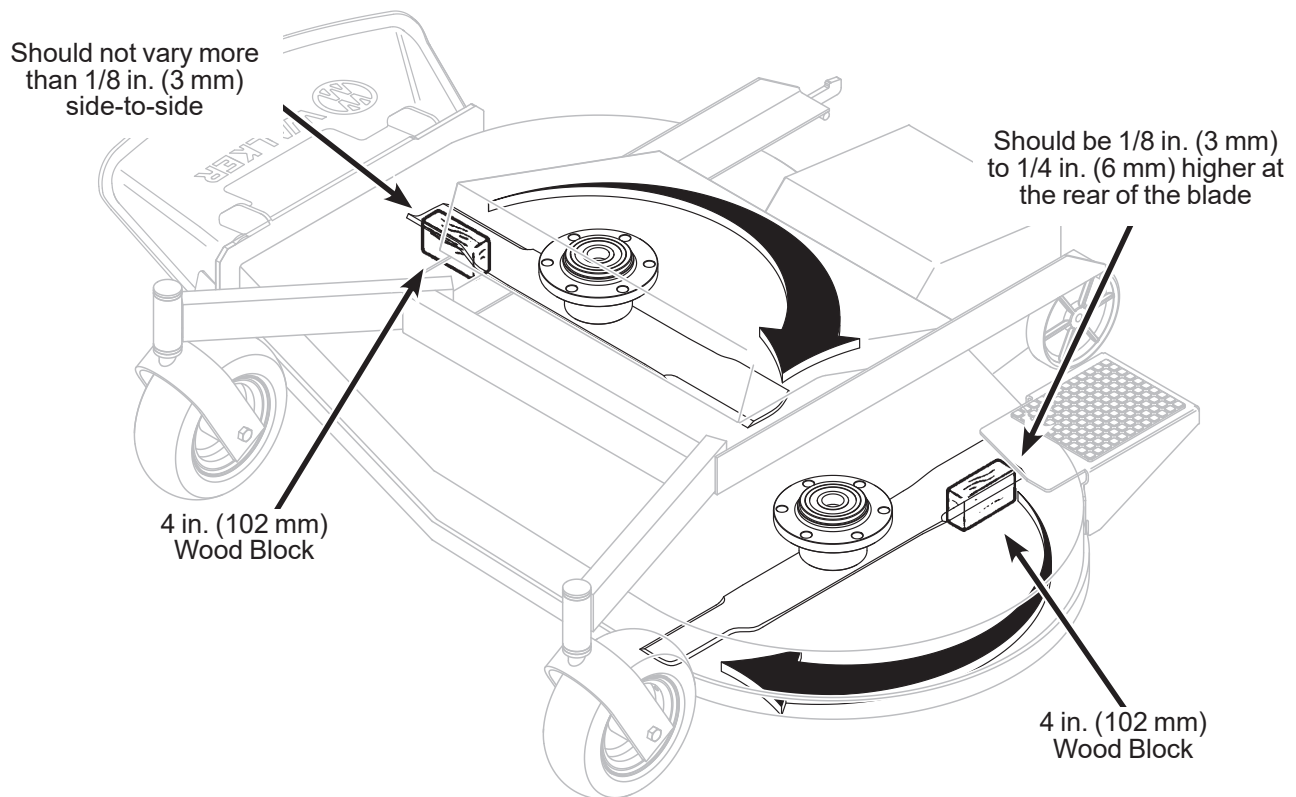

Deck Leveling

## Steering Handle Adjustment

An adjustment range of approximately 3 in. (76 mm) is available on the steering handles which allows the handles to be adjusted forward or aft depending on the arm length of the operator. The handles are adjusted by loosening the locknut at the pivot point and the locknut holding the handle in position in the adjustment slide. Adjust handles into most comfortable position and tighten both locknuts.

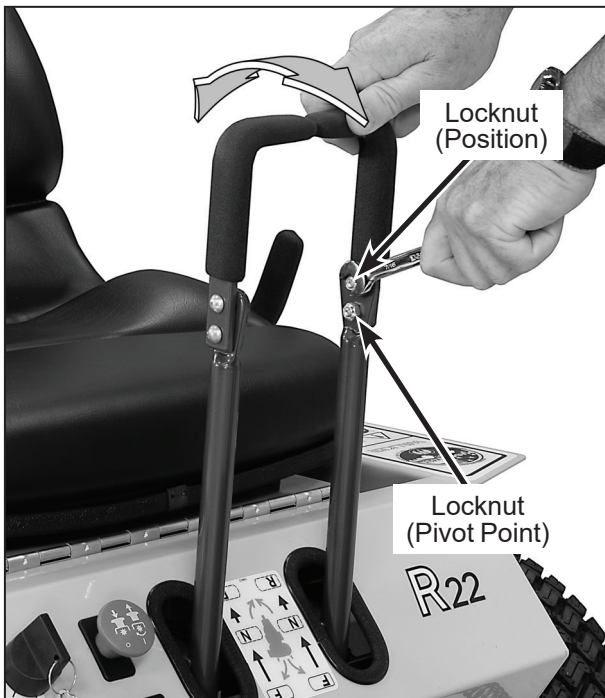

Steering Handle Adjustment

## Forward Speed Control Friction Adjustment

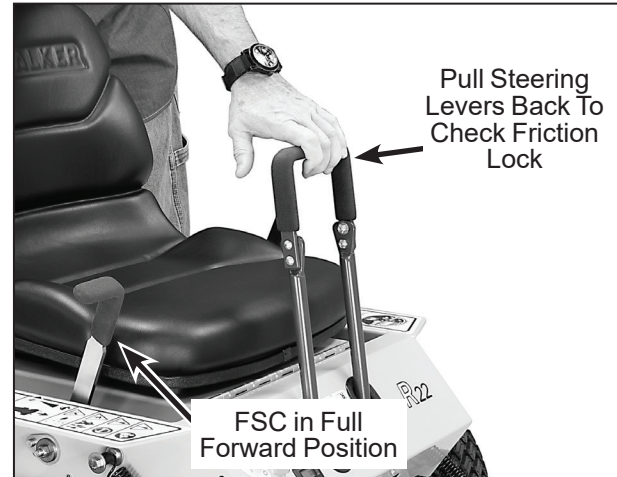

FSC Friction Adjustment Test

1. Place the FSC lever in the full **FORWARD** position, and pull both steering levers fully back; the FSC lever should not move. If the FSC lever moves back, the **friction needs to be increased**.
2. With the steering levers held back, move the FSC lever back from the **FORWARD** position. With a proper amount of friction adjusted, the FSC lever should move back with a slight amount of resistance (friction). If the FSC lever movement is "stiff", the **friction needs to be decreased**.
3. The FSC friction is increased or decreased by tightening or loosening the friction adjustment nut. Loosen or tighten the nut and check the control function until the conditions of both steps 1 and 2 (above) are met.

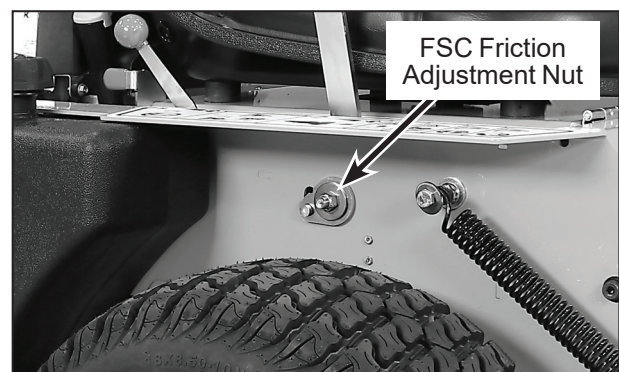

FSC Friction Adjustment Nut

## Neutral Function Adjustment

1. Securely block up tractor so the drive tires are a couple inches off the ground. The deck should remain attached.
2. Adjust the tracking adjustment nuts at the front of both control rods so that 2 or 3 threads are visible, then loosen the jam nuts on the ball joints at the back of the control rods.

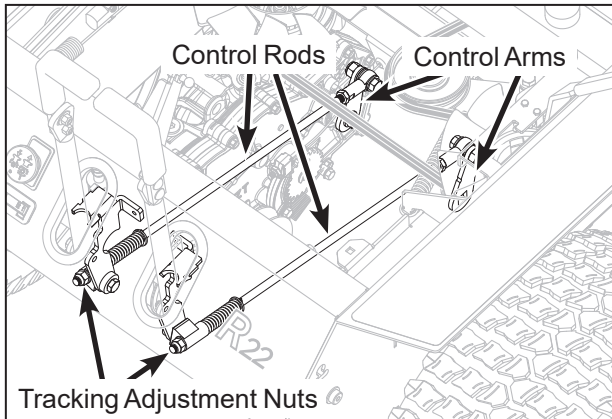

**Transmission Control Rod and Arm Location  
(Shown with Parts Removed for Clarity)**

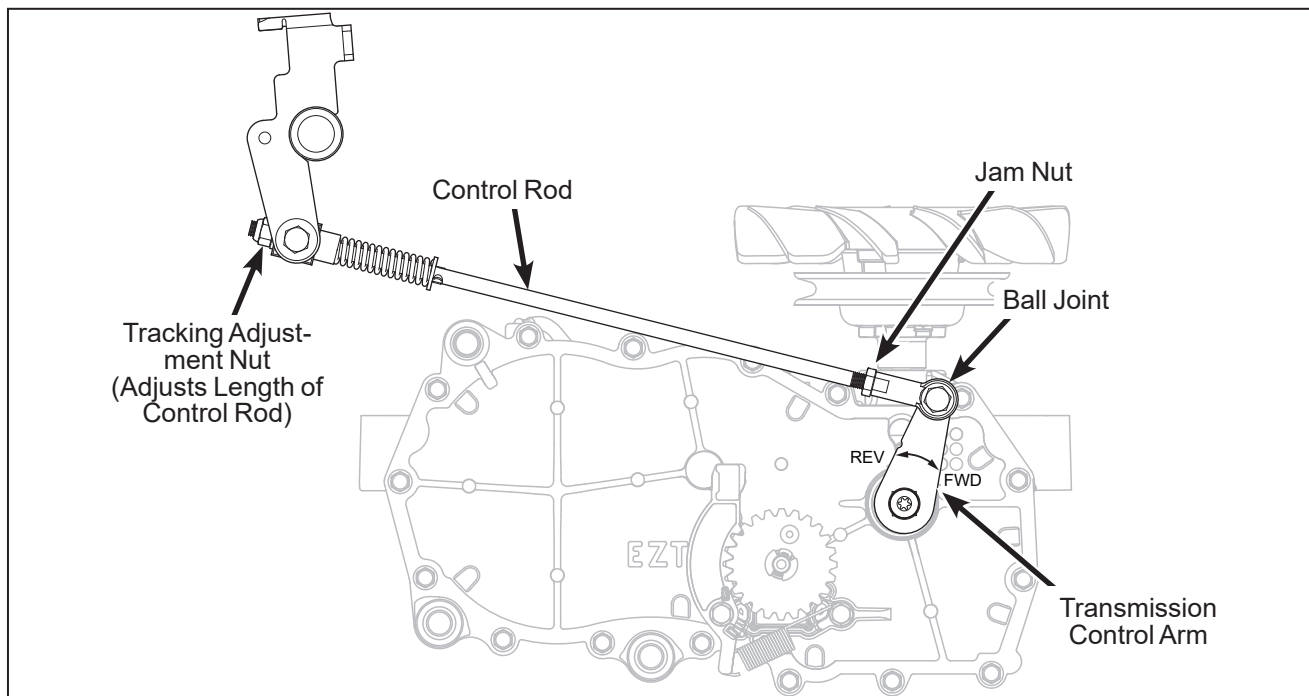

**Tracking Adjustment Components**

### **WARNING**

The following adjustments are made with the engine running. Keep all body parts and tools away from rotating and hot components, and secure all loose clothing.

3. With the seat panel lowered and the FSC in **NEUTRAL-PARK**, start the engine. With the engine at normal operating speed, check for movement of the drive wheels.
4. Using a wrench on one tracking adjustment nut, rotate the control rod **counterclockwise** just until the wheel on that side begins to **move forward**. Then, counting the turns required, rotate the control rod **clockwise** just until the wheel stops and then begins to **move in reverse**. Rotate the control rod back counterclockwise half the number of turns required to make the wheel go from moving forward to reverse. The transmission is now centered in the neutral window. Tighten the jam nut on the ball joint and repeat the same procedure on the other transmission.
5. Turn off the engine, and then lower the drive tires onto the ground.

## Straight Tracking Adjustment

1. Sit in the seat, start the engine, and set the throttle at full speed. With the FSC in the **NEUTRAL-PARK** position, check for movement of either drive wheel. If either wheel moves backward or forward, perform the "Neutral Function Adjustment" on page 59.
2. Check for straight ground tracking on a level surface (with hands off the steering levers). Set the FSC at several different speeds and observe if the machine moves in a straight line using a cement joint or other line on ground for reference.
3. If tracking is not straight, shorten the control rod on the **faster side** by turning the tracking adjustment nut of that side clockwise using 1/2 in. (13 mm) wrench.

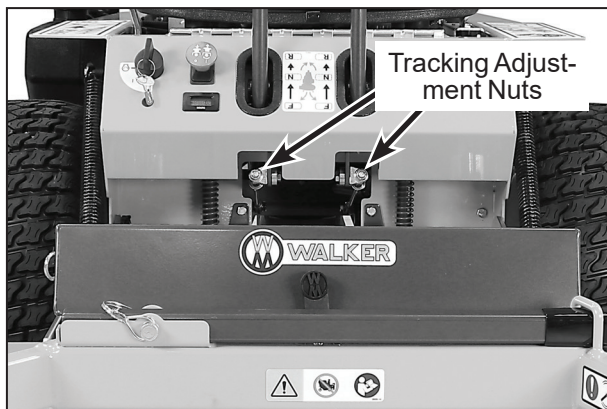

Tracking Adjustment Nuts

**NOTE:** If tracking issues only occur at **maximum speed**, proceed to the next step.

- If straight tracking and neutral are both achieved, the adjustment is complete.
- If straight tracking and neutral cannot both be achieved, turn the tracking adjustment nut on the faster side counterclockwise until neutral is restored. Lengthen the control rod on the slower side by turning the

tracking adjustment nut counterclockwise until straight tracking and neutral are both achieved.

**IMPORTANT:** After tracking adjustments are complete, confirm that there is at least one (1) thread visible on both control rods past the tracking adjustment nuts.

## Maximum Forward Speed Adjustment

If the machine is tracking straight throughout the speed range except at maximum speed, use the following adjustment procedure:

1. Raise the seat panel to access the maximum speed adjustment set screw. Loosen the jam nut and turn the adjustment screw counterclockwise to allow the FSC lever to move (over-travel) to the full forward position.
2. Lower the seat to the normal operating position and observe if one steering lever is ahead of the other. Raise the seat and turn the adjustment screw clockwise until the steering levers are aligned with each other with the FSC lever full forward (this may take several trials to bring the levers to alignment). Tighten the jam nut.
3. Test drive the machine to confirm that straight tracking is being achieved at maximum forward speed (FSC lever in full forward position).

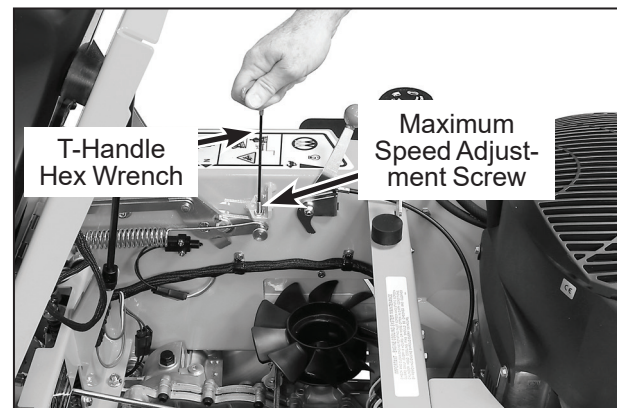

Maximum Speed Tracking Adjustment



# Appendix: Assembly Instructions

## In This Section...

Assembling the Tractor.....	61
Assembling the Deck.....	62
Installing the Deck.....	63



### WARNING

It is critical to follow the steps provided for setup and assembly of the tractor and deck to ensure the safety of the operator and performance of the equipment.

Walker Mowers are shipped partially assembled to our distribution network. These steps should be completed before the customer takes possession of their new mower.

## Assembling the Tractor

The following steps need to be performed to prepare the R22 for initial use after shipment from the factory.

1. Install the seat.
  - A. Remove the protective sheet from the seat panel.
  - B. Install the seat using the four (4) 1-1/4 x 3/4 Shock Mounts and 5/16-18 Whiz Lock-nuts supplied on the bottom of the seat.
  - C. Connect the safety switch wire harness to the receptacle on the bottom of the seat.
2. Install the steering lever handles. The steering lever handles and necessary hardware are included in the hardware bag. Attach each handle using two (2) 1/4-20 x .770 Knurled bolts and 1/4-20 self-locking nuts and one (1) .625 x .040 washer on the adjustment slot.



Steering Lever Handles Installed

3. The tires ship installed. Check and adjust the inflation of the tires. The tire inflation recommendations are:

Drive	=	15 PSI (103 kPa)
Tailwheel	=	20 PSI (137 kPa)

For tractors shipping outside the US the following additional steps will need to be performed.

4. Add fuel to the gas tank. Use only clean, fresh automotive grade **unleaded** gasoline (87 octane minimum, 10% ethanol maximum).

**IMPORTANT: DO NOT** permit dirt or other foreign matter to enter the fuel tank. Wipe dirt from around the filler cap before removing. Use a clean fuel storage container and funnel.

**IMPORTANT: DO NOT** mix oil with gasoline. Always use fresh, automotive grade unleaded gasoline. **DO NOT** use gasoline containing greater than 10% ethanol. **DO NOT** use additives, such as carburetor cleaners, deicers, or moisture removing agents. **DO NOT** use gasoline blended with methyl alcohol.

## Assembly Instructions for the R22

### **DANGER**

Handle gasoline with care. Gasoline is highly flammable and its vapors are explosive. Use safe refueling procedures:

- **DO NOT** smoke while refueling.
- Avoid spilling fuel; use a funnel or spout.

5. Connect the battery cable to the negative battery terminal using the hardware provided in the hardware bag. You will need a 1/4-20 x 5/8 hex bolt, a 1/4 SAE washer, and a 1/4-20 Keps nut to make the cable connection. Slide the rubber boot up and over the battery post completely to prevent an electrical short.

## Assembling the Deck

### **CAUTION**

The engine must be off during the tractor assembly and deck installation.

The following steps prepare the deck for the R22 for initial use after shipment from the factory.

### Deck Caster Wheel Installation

1. Remove the bolt and nut from each deck caster wheel fork.
2. Fit a bearing cup on the outside of each wheel bearing and slide the wheel assembly into the wheel fork.
3. Insert the 3/8-16 x 4-1/2 in. bolt through the wheel fork with the bolt head to the outside and install the 3/8-16 Keps nut.
4. Tighten the bolt and nut until the axle spacer tube and inner bearing race bottom against the inside of the wheel fork (will not turn) while the wheel spins freely without binding.

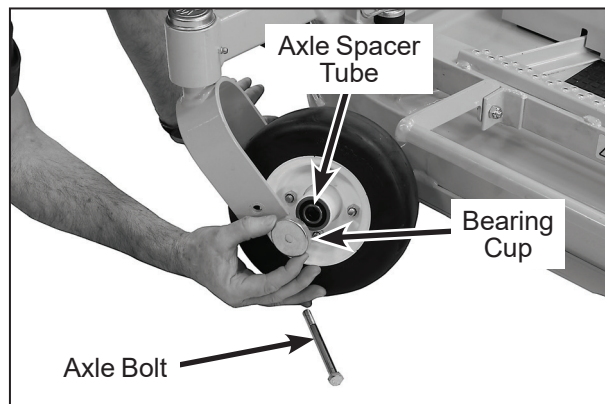

**Deck Caster Wheel Installation**

5. Grease the caster wheel bearings and caster pivot bearings—two (2) grease fittings for each wheel.

### Tilt-Up Roller Wheel Installation

Mount the two (2) tilt-up roller wheels on the brackets on the rear skirt of the deck housing using the axle bolt (Walker P/N 8490), 3/8 in. plain washer, 3/8 in. wave spring washer (between bracket and wheel) and 3/8-16 Whiz locknut. Tighten the axle bolt until the wheel rolls freely but is not loose.



**Roller Wheel Installation**

## Installing the Deck

### CAUTION

The engine must be off during the tractor assembly and deck installation.

### WARNING

Part of this procedure can be more easily accomplished with two (2) people.

1. Remove and discard the shipping link from the RH deck support arm by clipping the cable tie.



**Shipping Link on RH Deck Support Arm**

2. Install the two (2) deck counterweight springs on the tractor posts. Make sure the spring hooks are positioned to the outside between the rubber spacer tube and the washer. Do not place the spring on the spacer tube.

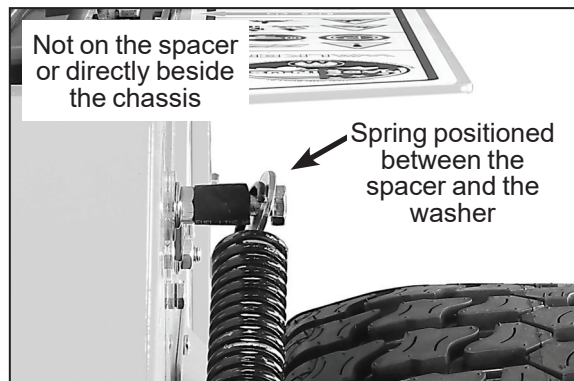

**Counterweight Spring Installed on Tractor Post**

3. Lift the deck belt access panel to verify the belt placement. The belts should run flat between the pulleys.

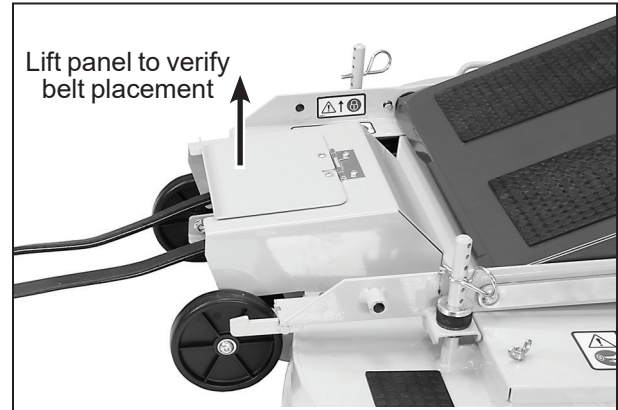

**Belt Access Panel**

4. Roll the deck to the tractor with the excess belt sliding under the tractor and align the carrier frame with the deck arms.

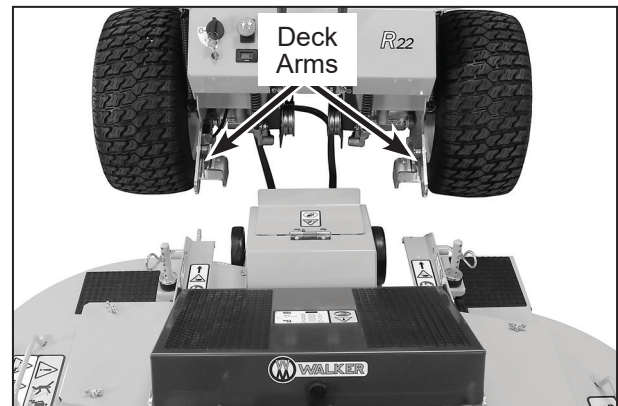

**Deck Arms Aligned with Carrier Frame**

5. Lift the carrier frame and install the 7/16-14 x 2 carriage bolt on each side. Position the bolts so the nuts will face out.

## Assembly Instructions for the R22

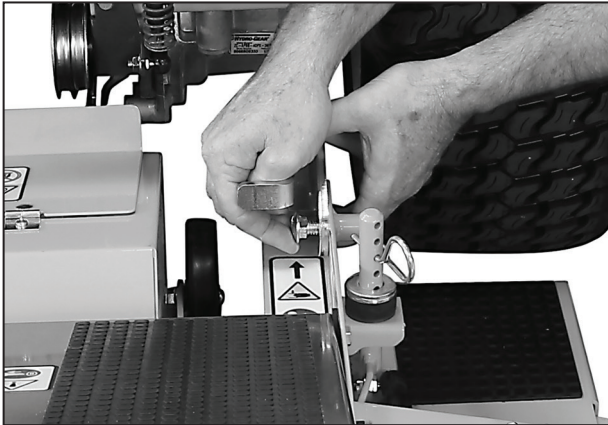

Install Carriage Bolt

6. Push down the deck lock lever, lift up the carrier frame, and release the deck lock lever to lock the deck pivot hinge on each side.

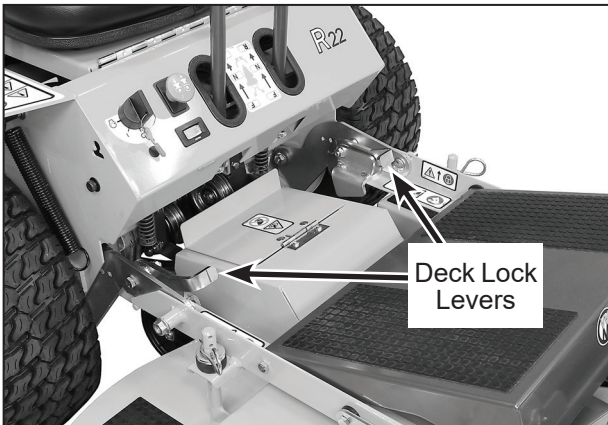

Deck Pivot Hinges Locked

7. Install the deck tilt bar and with the aid of a second person, lift the front of the deck. Slide the deck counterweight spring over the end of each carriage bolt onto the carrier frame.

**NOTE:** If a second person is not available, lift the front of the deck and place blocks under the front wheels to secure the deck before installing the counterweight springs.



Install Counterweight Spring on Carrier Frame

**IMPORTANT:** Make sure the counterweight spring hook is connected to the post on the carrier frame and not on the carriage bolt.



Counterweight Spring on Carrier Frame

8. Lower the deck and install the nut onto each carriage bolt. Using a 11/16 in. wrench, tighten the nuts and **then loosen** them **1/2 turn** until the pivot joint moves freely to allow for the deck to pivot and tilt up.



Install Nut on Carriage Bolt

## Assembly Instructions for the R22

9. Raise the footrest.
10. Remove the four (4) wing nuts on the deck belt cover and slide the cover out.
11. **For a 42", 48" deck:** Remove the belt from the LH spindle pulley.

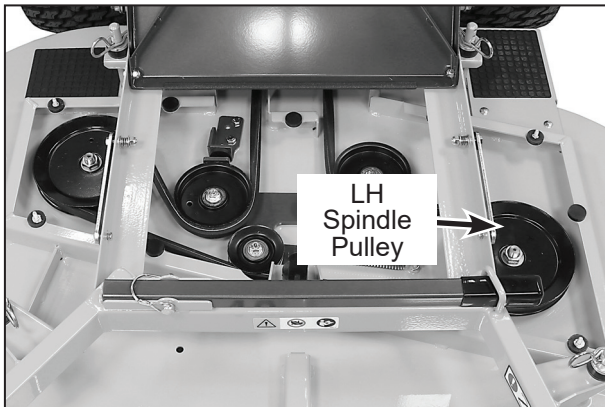

**42", 48" Deck: Remove Belt from LH Spindle Pulley**

**For a 54" deck:** Remove the extension spring, and remove the belt from the RH spindle pulley.

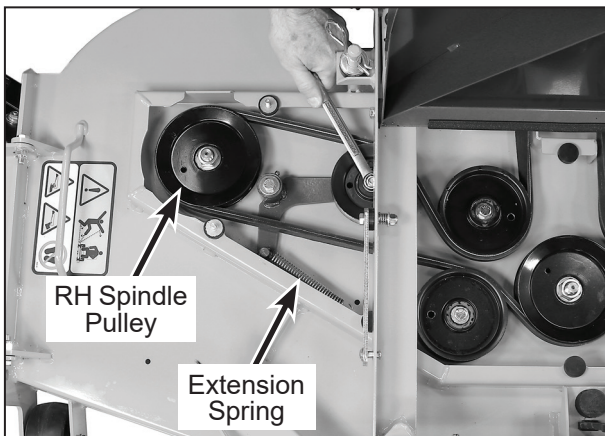

**54" Deck: Remove Belt from RH Spindle Pulley**

12. Lift the seat panel. Unlock and lift the belt tensioner lever to disengage.
13. On the engine side, position the belt between the rear idler pulleys and around the clutch pulley. Be sure to add the 1/4 twist on each side forward of the rear idler pulleys. See the Belt Routing Decal for details.

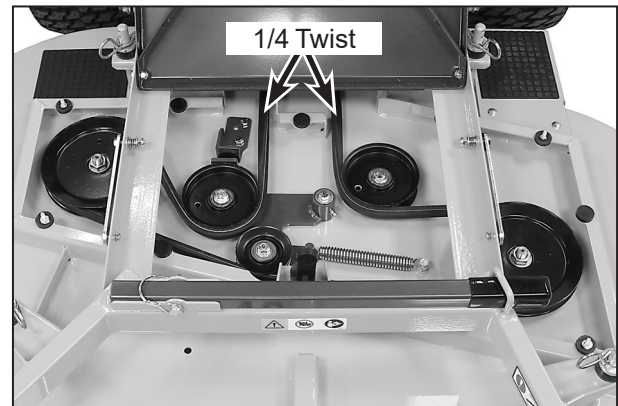

**Quarter Twist on Each Side**

**NOTE:** The Belt Routing decal located under the seat panel shows correct belt placement.

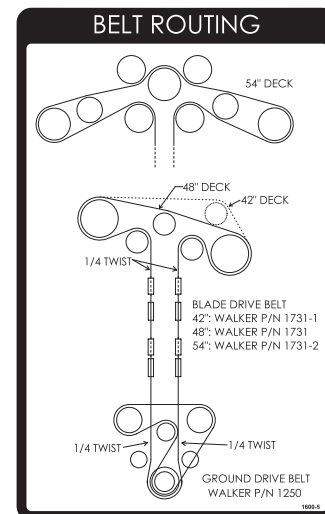

**Belt Routing Decal**

14. Re-tension the blade drive belt in the deck.  
**For a 42", 48" deck:** Push back on the tensioned idler, and reinstall the belt around the LH spindle.  
**For a 54" deck:** Pull back on the RH V-groove idler to rotate the deck idler arm and reinstall the extension spring.
15. Re-engage the belt tensioner lever in the tractor by pushing down on it. The lock will automatically engage. Lower the seat panel.

**NOTE:** The pulley beside the tensioner extension spring may need to be pushed down to increase clearance for the tensioner arm before the lever can be engaged.

## Assembly Instructions for the R22

16. Check and adjust the effective belt length.  
With the drive belt in place, check the position of the front idler on the tensioning arm. The top of the idler should be even with to 1/2" below the edge of the chassis. If the idler is too high, adjust the positions of the deck idlers to effectively lengthen the belt. If the idler is too low, adjust the positions of the deck idlers to effectively shorten the belt.

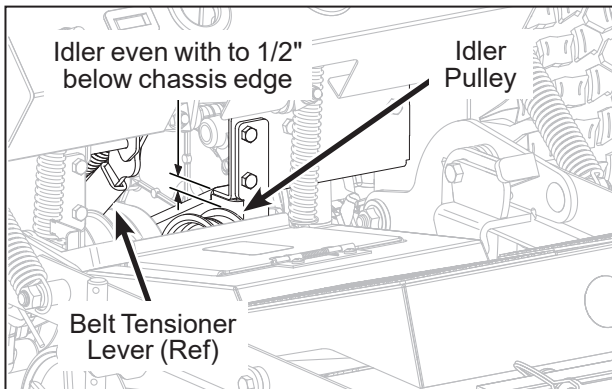

**Check Position of Front Idler on Tensioning Arm**

**For a 42", 48" deck:** To adjust for variations in belt length, the idler stop has two (2) mounting positions; it can be mounted forward to effectively shorten the drive belt or back to lengthen the belt. It comes from the factory mounted in the back position. The LH fixed idler has three (3) mount holes to effectively shorten or lengthen the belt and it comes from the factory mounted in the middle hole. Use any combination of mounting the idler stop and LH idler pulley to adjust for the correct **Position of Front Idler on Tensioning Arm** (as shown in illustration).

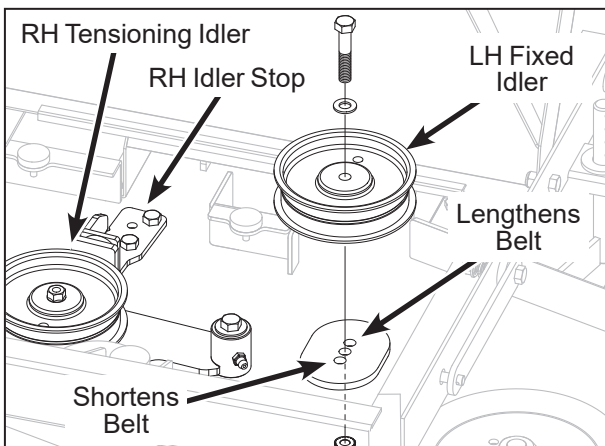

**Adjust Effective Belt Length (42", 48")**

**For a 54" deck:** The RH and LH fixed idlers can be moved forward (one or both) to effectively shorten the belt. They come mounted in the rear holes from the factory.

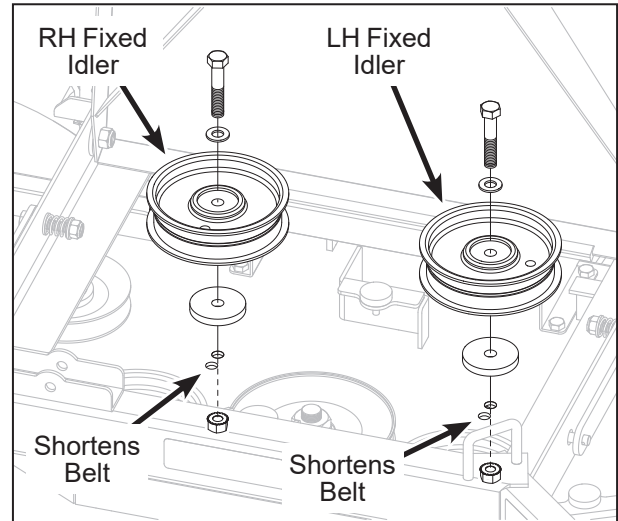

**Adjust Effective Belt Length (54")**

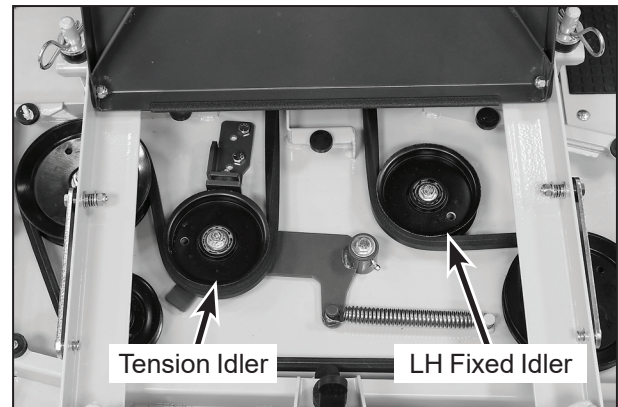

**Idler Pulleys (42" Shown)**

17. Reinstall the belt cover on the deck.

18. Lower the footrest.

# **LIMITED WARRANTY FOR WALKER MODEL R22 RIDER MOWERS**

## **1. WHAT THIS WARRANTY COVERS, AND FOR HOW LONG:**

Walker Manufacturing company will, at its option, repair or replace, without charge, any part covered by this warranty which is found to be defective in material and/or workmanship within three (3) years or 300 hours whichever comes first after date of sale to the original retail purchaser. At Walker's request, customer will make the defective part available for inspection by Walker and/or return the defective part to Walker, transportation charges prepaid. All parts and components of the Walker Mower are covered by this warranty **except** the following components which are warranted separately by their respective manufacturers:

Kohler Engine

Battery

The available warranties covering these items are furnished with each mower. Walker does not assume any warranty obligation, liability or modification for these items, which are covered exclusively by the stated warranty of the respective manufacturers noted above.

## **2. WHAT THIS WARRANTY DOES NOT COVER:**

- A. This warranty does not cover defects caused by depreciation or damage caused by normal wear, accidents, improper maintenance, improper use or abuse of the product, alterations, or failure to follow the instructions contained in the Operator's Manual for operation and maintenance.
- B. The customer shall pay any charges for making service calls and/or for transporting the mower to and from the place where the inspection and/or warranty work is performed.

## **3. HOW TO OBTAIN SERVICE UNDER THIS WARRANTY:**

Warranty service can be arranged by contacting the dealer where you purchased the mower or by contacting Walker Manufacturing Company, 5925 East Harmony Road, Ft. Collins, CO 80528. Proof of the date of purchase may be required to verify warranty coverage.

## **4. WARRANTY LIMITATION:**

- A. **THERE IS NO OTHER EXPRESS WARRANTY. ANY WARRANTY THAT MAY BE IMPLIED FROM THIS PURCHASE INCLUDING MERCHANTABILITY AND FITNESS FOR A PARTICULAR PURPOSE IS HEREBY LIMITED TO THE DURATION OF THIS WARRANTY AND TO THE EXTENT PERMITTED BY LAW ANY AND ALL IMPLIED WARRANTIES ARE EXCLUDED.** Some states do not allow limitations on how long an implied warranty lasts, so the above limitations may not apply to you.
- B. **WALKER WILL NOT BE LIABLE FOR ANY INCIDENTAL, CONSEQUENTIAL, OR SPECIAL DAMAGES AND/OR EXPENSES IN CONNECTION WITH THE PURCHASE OR USE OF THE MOWER.** Some states do not allow the exclusion or limitation of incidental or consequential damages, so the above limitation(s) or exclusion(s) may not apply to you.
- C. Only the warranty expressed in this limited warranty shall apply and no dealer, distributor, or individual is authorized to amend, modify, or extend this warranty in any way. Accordingly, additional statements such as dealer advertising or presentations, whether oral or written, do not constitute warranties by Walker, and should not be relied upon.
- D. This warranty gives you specific legal rights, and you may also have other rights which vary from state to state.



**WALKER**

**WALKER MFG. CO. • 5925 E. HARMONY ROAD, FORT COLLINS, CO 80528 • (970) 221-5614**  
**FORM NO. 042324      PRINTED IN USA      [www.walker.com](http://www.walker.com)      ©2024 WALKER MFG. CO**